



Manufactured by:
Backyard Discovery
3305 Airport Drive, Pittsburg, KS 66762
800-856-4445

Basepoint Business Centre: Rivermead Drive, Westlea, Swindon SN5 7EX Phone: 0800-118-2476
J.P. Coenstraat 7, The Bridge, The Hague, 2595 WP, Netherlands Phone: 08005678990

12x10 BRINDLEWOOD GAZEBO AU

MODEL # : 2106550B

**THE ASSEMBLY MANUAL MUST BE RETAINED
SINCE IT CONTAINS IMPORTANT INFORMATION**



Please visit www.backyarddiscovery.com
For the most up to date assembly manual, to register your product, or to order
replacement parts *Para obtener instrucciones en español, visite*
www.backyarddiscovery.com



EASY STEP-BY-STEP
3D INTERACTIVE INSTRUCTIONS
DOWNLOAD THE FREE APP



Made in China

INS-2106550B-A-12x10 BRINDLEWOOD GAZEBO AU-ENG 02-10-2023

OWNER'S MANUAL - BASIC SETUP DIMENSIONS & ASSEMBLY NOTES

It is critically important that you start with square and level footings, concrete pad or deck to attach your structure

- Pay close attention to the items needed for each step. Make sure you are using the correct hardware for each step. Using incorrect hardware may result in improper assembly
- Remember to double check for underground utilities and overhead electrical lines

Post mounts are provided with your structure which allows you to permanently install your structure to a pre-existing or new wood or concrete surface. See Anchor Instructions for further details and recommendations.

- The hardware to attach the post mounts to the structure is included.
- The hardware to mount the structure permanently to a concrete surface is included.
- The hardware to mount the structure permanently to a wood deck is NOT included and will need to be purchased separately. You must ensure there is ample structural support under the deck before permanently attaching.

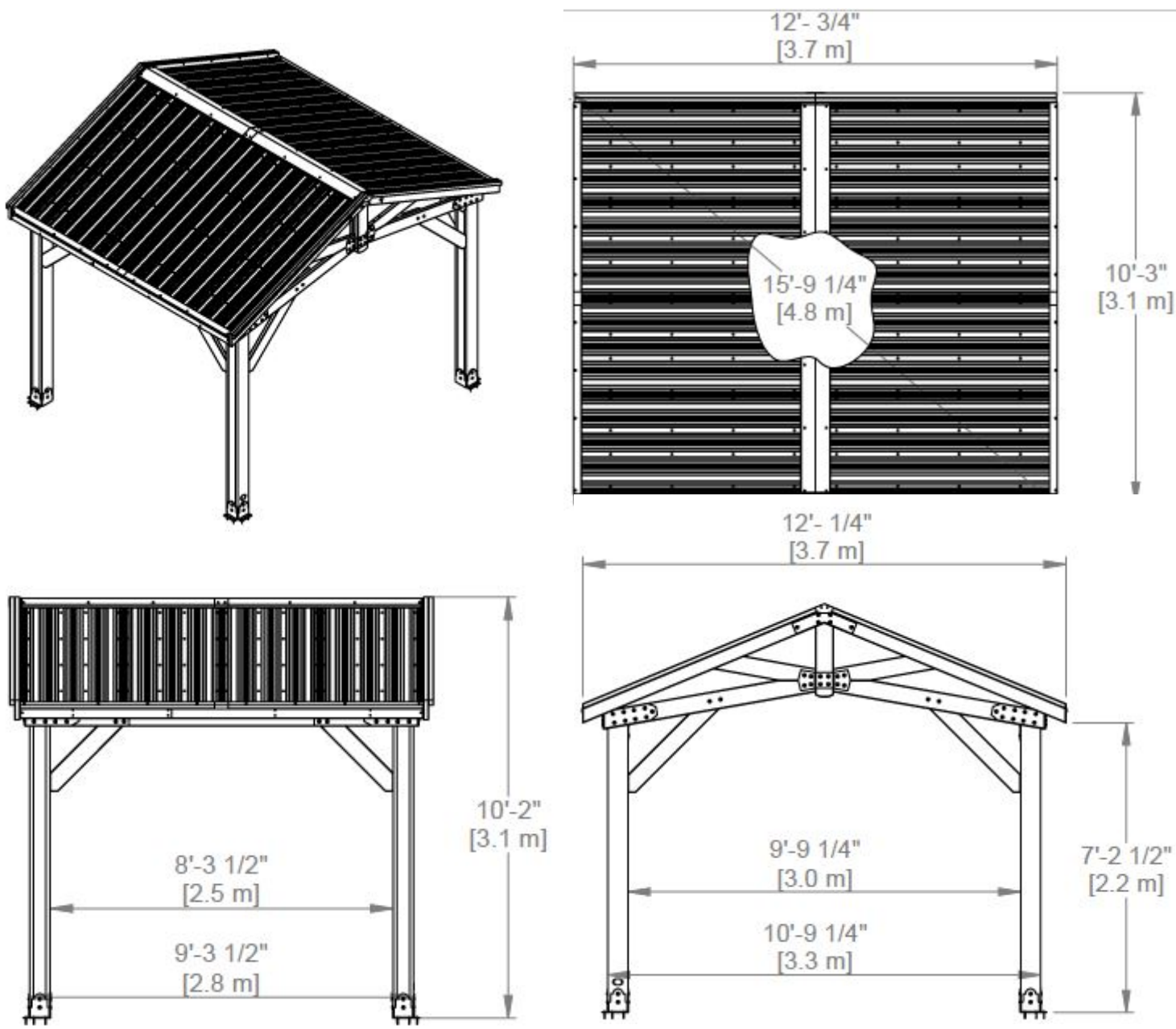

OWNER'S MANUAL - ANCHORING LAYOUT

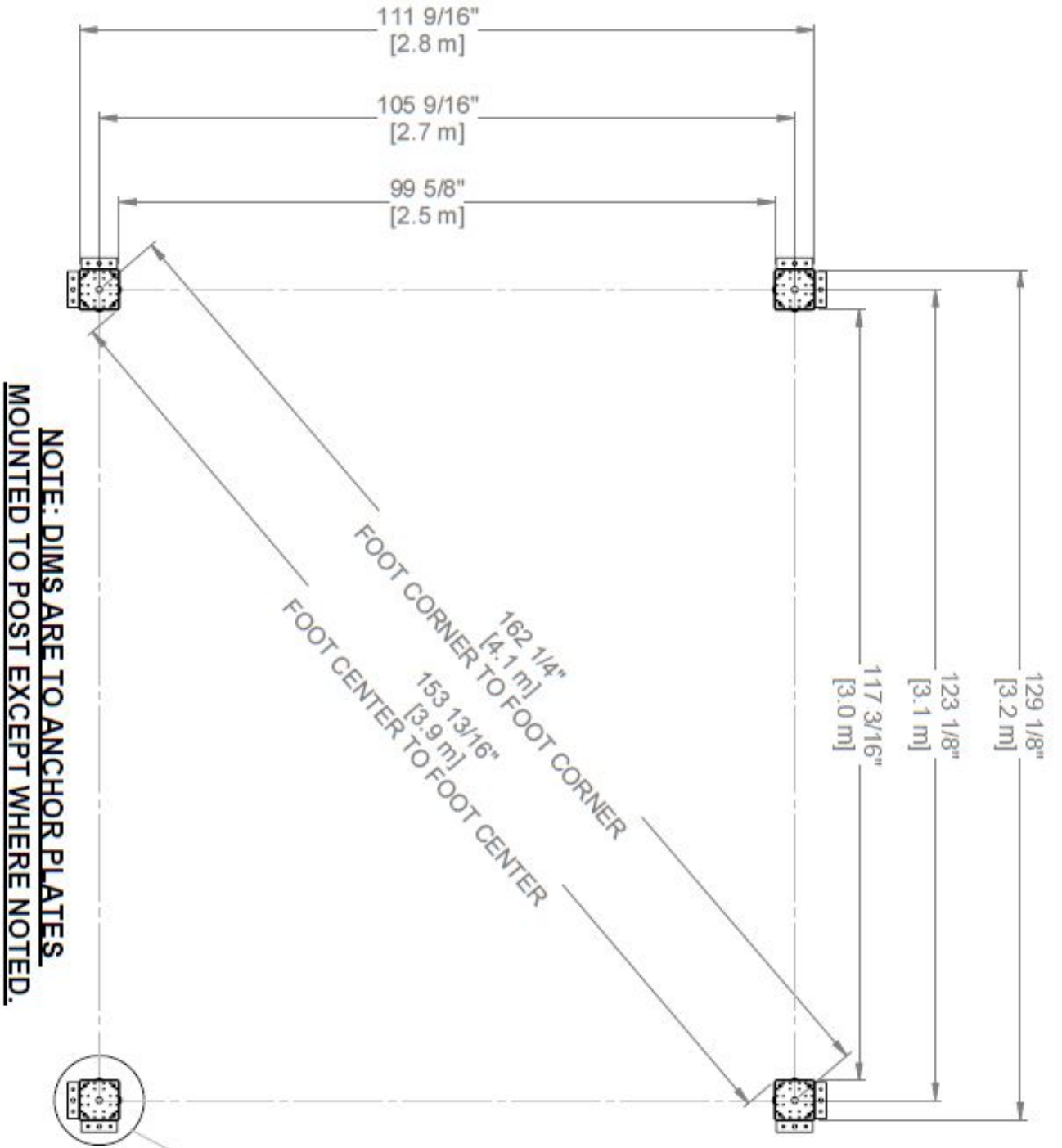

NOTE: DIMS ARE TO ANCHOR PLATES MOUNTED TO POST EXCEPT WHERE NOTED.

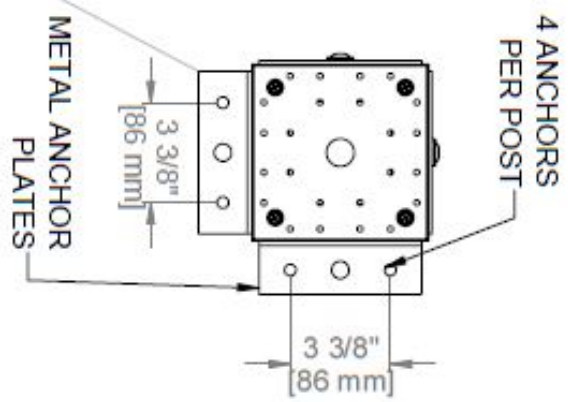
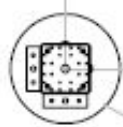

OWNER'S MANUAL - PARTS IDENTIFICATION

Wood Components (Not to Scale)



J9 | RIDGE CAP STIFFENER-W4L13590
(x2) | 15/16"x2 3/8"x47 5/8" (24x60x1210)



J10 | RIDGE CAP STIFFENER-W4L13591
(x2) | 15/16"x2 3/8"x69 5/16" (24x60x1760)



D1 | GABLE BOARD-W4L16231
(x4) | 1 7/16"x5 1/4"x24 3/16" (36x134x615)



D2 | TOP RAIL-W4L17221
(x4) | 1 7/16"x5 1/4"x30 5/16" (36x134x770)



D3 | TOP RAIL-W4L17222
(x2) | 1 7/16"x5 1/4"x64 5/16" (36x134x1634)



D4 | CORBEL-W4L16234
(x3) | 1 7/16"x5 1/4"x35 7/8" (36x134x910)

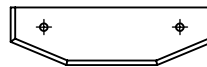

D5 | GABLE BOARD-W4L16235
(x2) | 1 7/16"x1 1/2"x5 1/4" (36x38x134)



D6 | CORBEL-W4L17223
(x4) | 1 7/16"x5 1/4"x45 7/8" (36x134x1165)

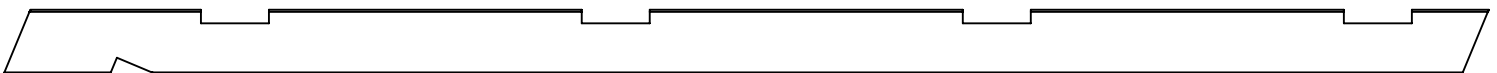

E1 | RAFTER-W4L16237
(x8) | 1 7/16"x3 3/8"x77 3/8" (36x86x1965)



E2 | TRUSS-W4L16238
(x4) | 1 7/16"x1 15/16"x74 15/16" (36x50x1903)

OWNER'S MANUAL - PARTS IDENTIFICATION

Wood Components (Not to Scale)



E3 | SHEATHING BOARD-W4L16239
(x8) | 1 7/16"x3 3/8"x73 1/4" (36x86x1861)



E4 | SHEATHING BOARD-W4L16240
(x8) | 1 7/16"x3 3/8"x45 3/4" (36x86x1161)



H2 | FASCIA-W4L16241
(x2) | 15/16"x3 3/8"x74 11/16" (24x86x1896)

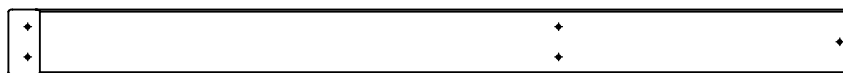

H3 | FASCIA-W4L16242
(x2) | 15/16"x3 3/8"x44" (24x86x1118)



H4 | RAFTER-W4L16243
(x2) | 15/16"x3 3/8"x39 13/16" (24x86x1011)



H5 | RAFTER-W4L16244
(x2) | 15/16"x3 3/8"x70 7/16" (24x86x1789)

OWNER'S MANUAL - PARTS IDENTIFICATION

Wood Components (Not to Scale)

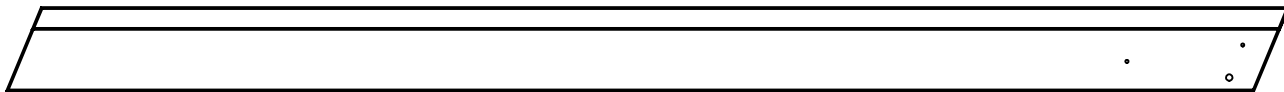

GP1 | GABLE PANEL-W2A03379
(x2) | 2 13/16"x5 1/4"x80 3/16" (72x134x2037)

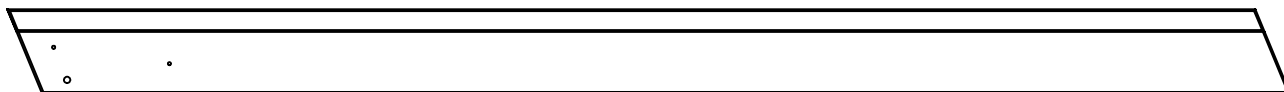

GP2 | GABLE PANEL-W2A03380
(x2) | 2 13/16"x5 1/4"x80 3/16" (72x134x2037)

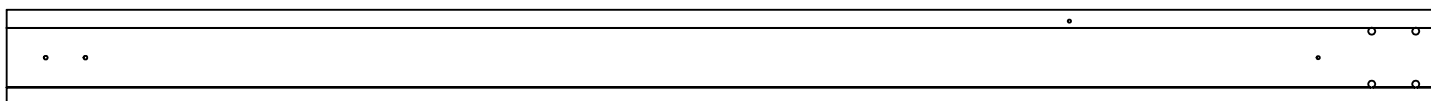

P1 | POST-W2A03517
(x2) | 6"x6"x89 1/2" (152x152x2274)

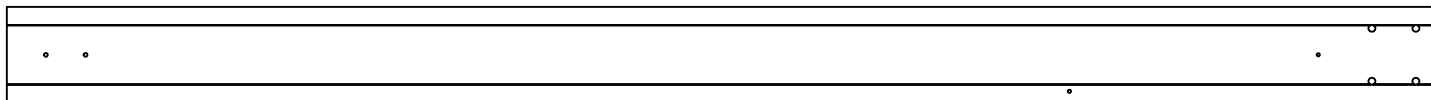

P2 | POST-W2A03518
(x2) | 6"x6"x89 1/2" (152x152x2274)

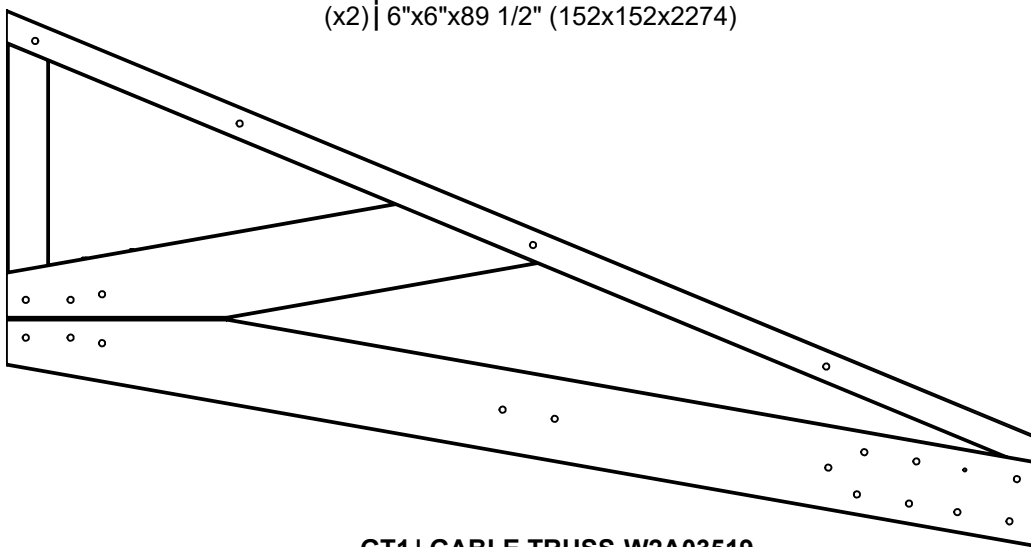

GT1 | GABLE TRUSS-W2A03519
(x4) | 1 7/16"x33 5/8"x64 9/16" (36x854x1640)



D7 | CORBEL W/TAG-W2A03384
(x1) | 1 7/16"x5 1/4"x35 13/16" (36x134x910)

OWNER'S MANUAL - PARTS IDENTIFICATION

Hardware Components (Not to Scale)

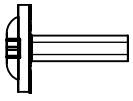

H100468 | BOLT WH BLK
(x22) | 5/16x1

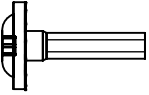

H100459 | BOLT WH BLK
(x54) | 5/16x1 1/4

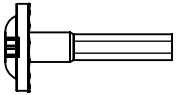

H100407 | BOLT WH BLK
(x3) | 5/16x1 1/2

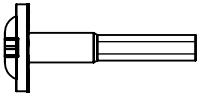

H100378 | BOLT WH BLK
(x2) | 5/16x1 3/4

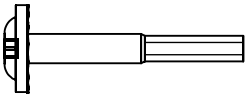

H100205 | BOLT WH BLK
(x26) | 5/16x2 1/4

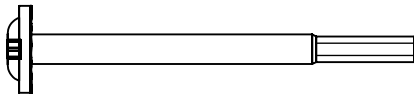

H100512 | BOLT WH BLK
(x9) | 5/16x4

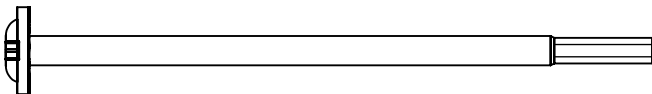

H100354 | BOLT WH BLK
(x34) | 5/16x6 1/2

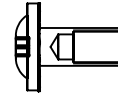

H100192 | NUT BARREL WH BLK
(x95) | 5/16x7/8

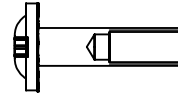

H100193 | NUT BARREL WH BLK
(x30) | 5/16x1 1/2

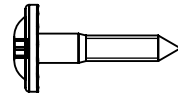

H100471 | LAG SCREW WH BLK
(x50) | 5/16x 1 1/2

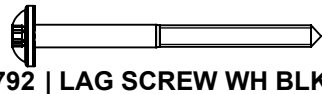

H100792 | LAG SCREW WH BLK
(x9) | 1/4x3



H100564 | LAG SREW WH BLK
(x13) | 1/4x4



H100379 | T-NUT BLK
(x18) | 5/16



H100479 | NUT LOCK BLK
(x4) | 5/16

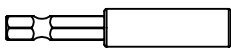

H101100 | MAGNETIC DRIVER
(x1)

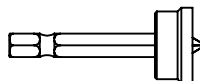

H100764 | SCREW SETTER
(x1)

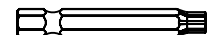

H100147 | TORX BIT
(x1) | T-30

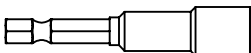

H101106 | SOCKET DRIVER
(x1) | 10mm



H100114 | TORX WRENCH
(x1) | T-30

OWNER'S MANUAL - PARTS IDENTIFICATION

Hardware Components (Not to Scale)



H100200 | SCREW PFH BLK
(x33) | 8x1 1/2



H100391 | SCREW PFH BLK
(x64) | 8x2



H100483 | SCREW PFH BLK
(x4) | 8x2 1/4



H100201 | SCREW PFH BLK
(x22) | 8x2 1/2



H100392 | SCREW PWH BLK
(x17) | 8x3/4



H100797 | SCREW PWH BLK
(x17) | 8x1



H100120 | SCREW CONCRETE ANCHOR
(x18) | 1/4x2" 1/4x2

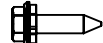

H100833 | SCREW WOODGRIP
(x17) | 10x3/4



H100405 | WASHER LOCK EXT BLK
(x22) | 6x15



H100198 | WASHER LOCK EXT BLK
(x47) | 8x19



H100199 | WASHER LOCK EXT BLK
(x63) | 12x19



H100630 | WASHER FLAT BLK
(x17) | 8x19



H100770 | WASHER FLAT BLK
(x4) | 5/16

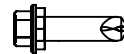

H100759 | SCREW TAPPING
(x17) | 1/4x3/4

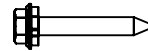

H100760 | SCREW WOODGRIP
(x132) | 10x1 1/4

OWNER'S MANUAL - PARTS IDENTIFICATION

Accessory Components (Not to Scale)

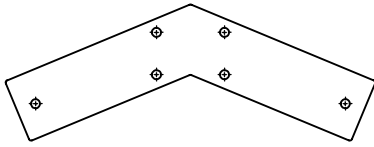

A4M01130 | GABLE BRACKET
(x2)



A4M01147 | PEAK SEAM BRACKET
(x2)

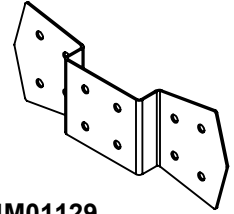

A4M01129 | GABLE BRACKET
(x4)

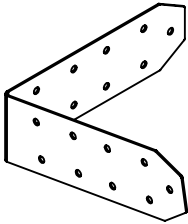

A4M01555 | LEFT OUTSIDE
BRACKET
(x2)

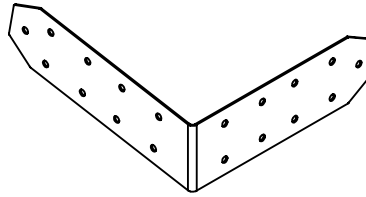

A4M01554 | RIGHT OUTSIDE
BRACKET
(x2)

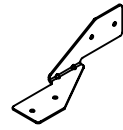

A4M01155 | TIE BRACKET
(x4)



A4M01793 | STEEL POST ANCHOR PLATE
(x8)



A4M01794 | POST PLATE
(x8)

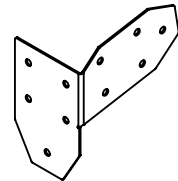

A4M01232 | LEFT ANGLE
BRACKET
(x2)

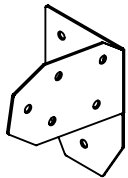

A4M01233 | RIGHT ANGLE
BRACKET
(x2)

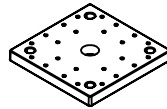

A6P00308 | 6x6 POST FOOT
(x4)



A4M01148 | TRUSS BRACKET
(x2)



A100241 | BYD ID TAG
(x1)

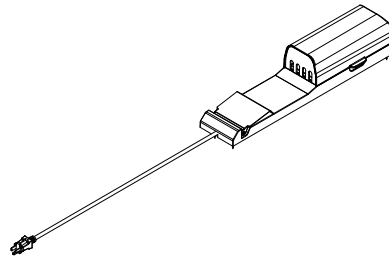

9220409 | POWERPORT
(x1)

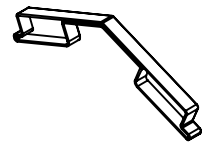

A6P00398 | RIDGE CAP
PROTECTOR
(x2)

OWNER'S MANUAL - PARTS IDENTIFICATION

Accessory Components (Not to Scale)

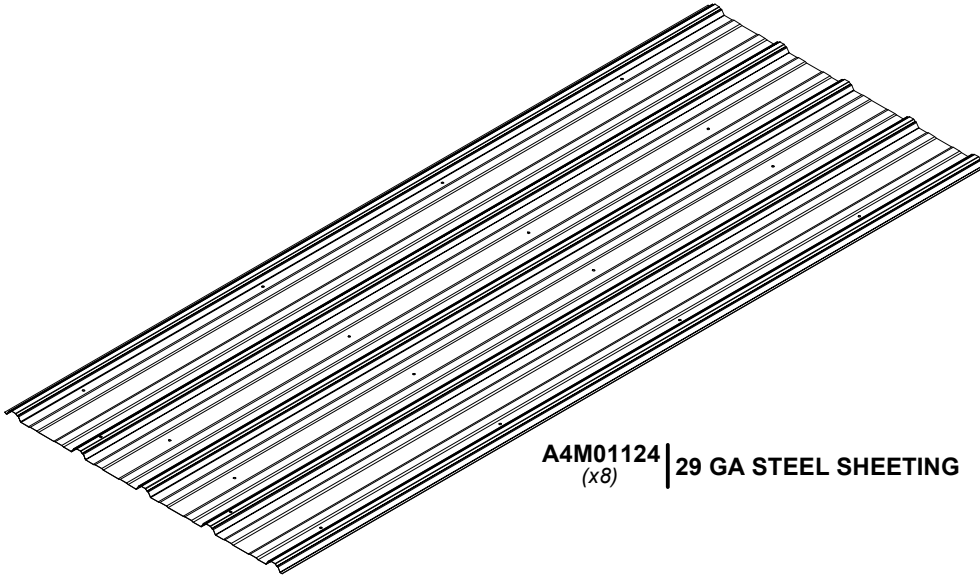

A4M01124 | 29 GA STEEL SHEETING
(x8)

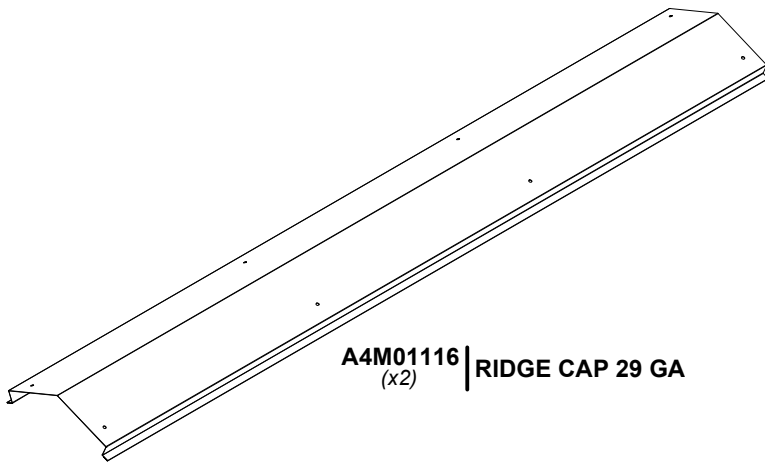

A4M01116 | RIDGE CAP 29 GA
(x2)

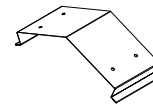

A4M01127 | RIDGE CAP SPLICE
(x1)



A4M00983 | ROOF EDGE TRIM SPLICE
(x2)

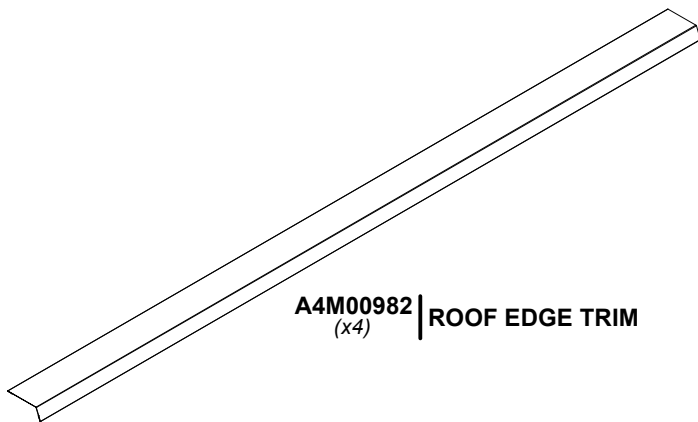

A4M00982 | ROOF EDGE TRIM
(x4)

PRE-ASSEMBLY STEP 1 - SORTING PARTS

It is critical for ease of assembly that you take the time to sort and organize the wood and hardware.

WOOD PARTS:

- Organize wood parts by the three-digit, alpha-numeric number stamped on each board (ex. P01).
- If there are multiple boards with the same stamped number, stack those pieces together.
- Stamps can be found on the flat surface of the boards or on the end of the boards.
- Allow yourself plenty of room - the wood pieces can take up a significant amount of space.

NOTE: CARTONS ARE NOT ORGANIZED BY BOARD NUMBER.



HARDWARE PARTS:

- We recommend that you have a separate table to organize the hardware.
- Hardware bags are printed with a seven-digit, alpha-numeric part number.
- You can organize your hardware by part number or group by hardware type (i.e. bolts, nuts, etc.).
- During assembly you only need to reference the last four digits of the number.

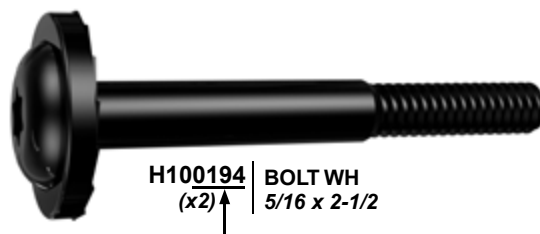

PRE-ASSEMBLY STEP 2 - TOOLS REQUIRED



Cordless Drill or Electric Drill



Drill Attachments:
Phillips Head



1/8", 3/16", 3/8" &
7/16" Drill Bits



Phillips Screw Driver



Open End
Wrenches 1/2" &
7/16"



3/8" Drive Ratchet, 1/2" &
7/16" STD Sockets, 1/2" &
7/16" Deep Sockets



Tape Measure



Claw Hammer



3/8 & 5/16" Nut Drivers

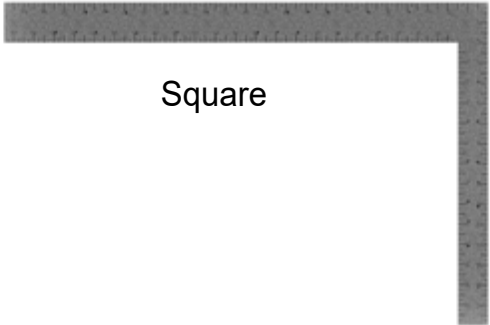

Square



Level 24"



Rubber Mallet -
Optional

PRE-ASSEMBLY STEP 3 - CHOOSE YOUR ASSEMBLY METHOD

There are several types of assembly instructions available to you.

1. Printed Assembly Manual included with your set
2. BILT APP - 3D interactive instructions
3. Combination of the Printed Manual and BILT APP (Note: Step numbers can differ between the two methods)

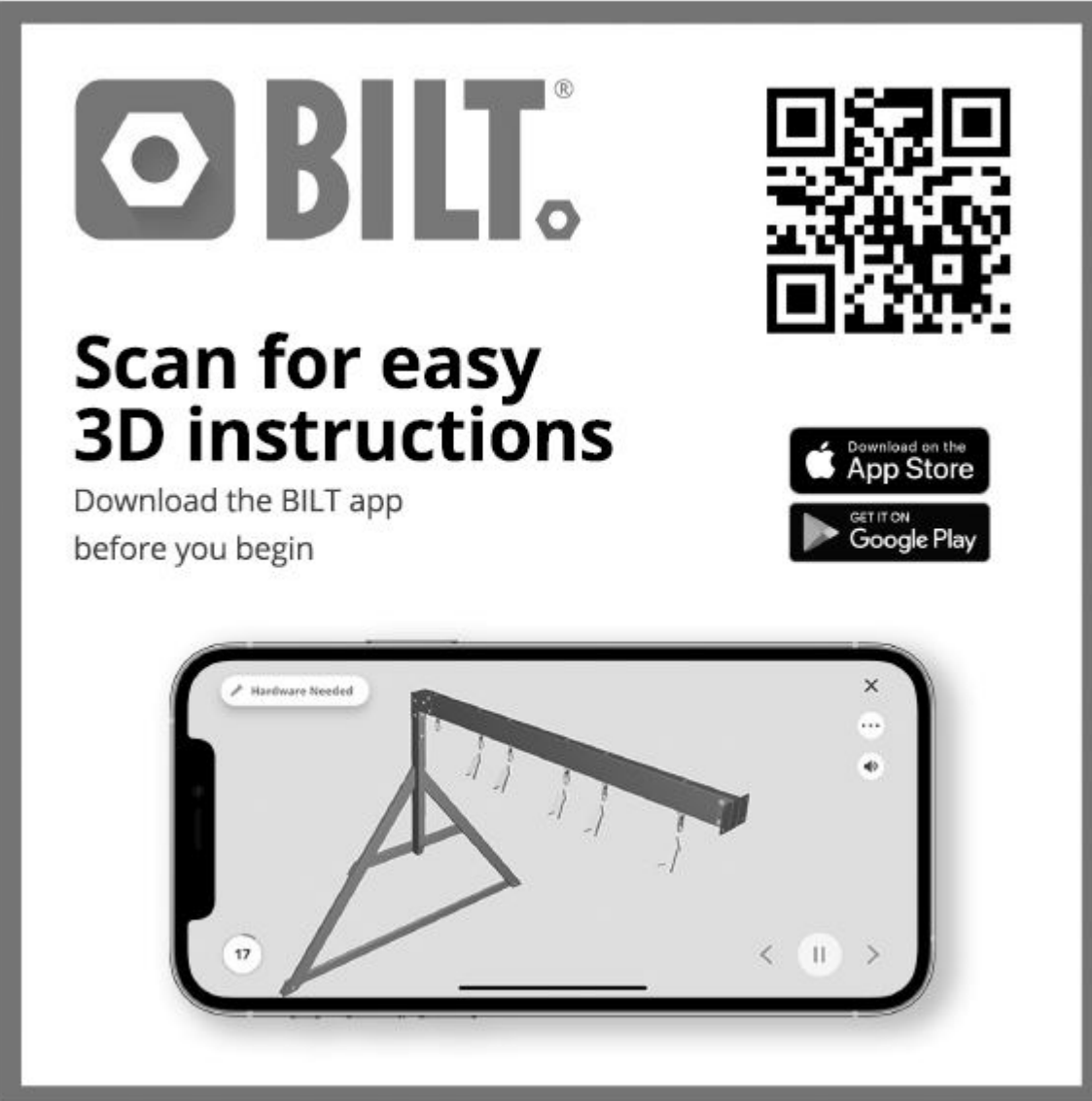

The graphic is a rectangular advertisement for the BILT app. At the top left is the BILT logo, which consists of a hexagonal icon with a white dot inside, followed by the word "BILT." in a bold, sans-serif font with a registered trademark symbol. To the right of the logo is a large QR code. Below the logo and QR code, the text "Scan for easy 3D instructions" is written in a large, bold, black font. Underneath this, in a smaller font, it says "Download the BILT app before you begin". To the right of this text are two buttons: "Download on the App Store" with the Apple logo and "GET IT ON Google Play" with the Google Play logo. At the bottom of the graphic is a smartphone displaying the BILT app interface. The screen shows a 3D model of a metal structure with a horizontal beam and several hanging components. The app interface includes a "Hardware Needed" button at the top left, a close button (X) at the top right, a list of icons in the middle right, and a page number "17" in a circle at the bottom left. At the bottom center of the screen are navigation arrows and a pause button.

STEP 1 - GAZEBO ASSEMBLY

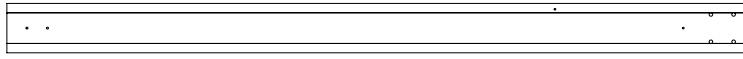

P1 | POST-W2A03517
(x2) | 6"x6"x89 1/2" (152x152x2274)

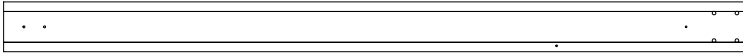

P2 | POST-W2A03518
(x2) | 6"x6"x89 1/2" (152x152x2274)

QTY	PART NUMBER	DESCRIPTION
16	H100200	SCREW PFH 8x1 1/2 BLK

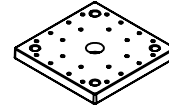

A6P00308 | 6x6 POST FOOT
(x4)

COMPLETE THIS STEP TWICE

FOR EASE OF ASSEMBLY, WE RECOMMEND USING SAW HORSES FOR STEPS 1 - 6.

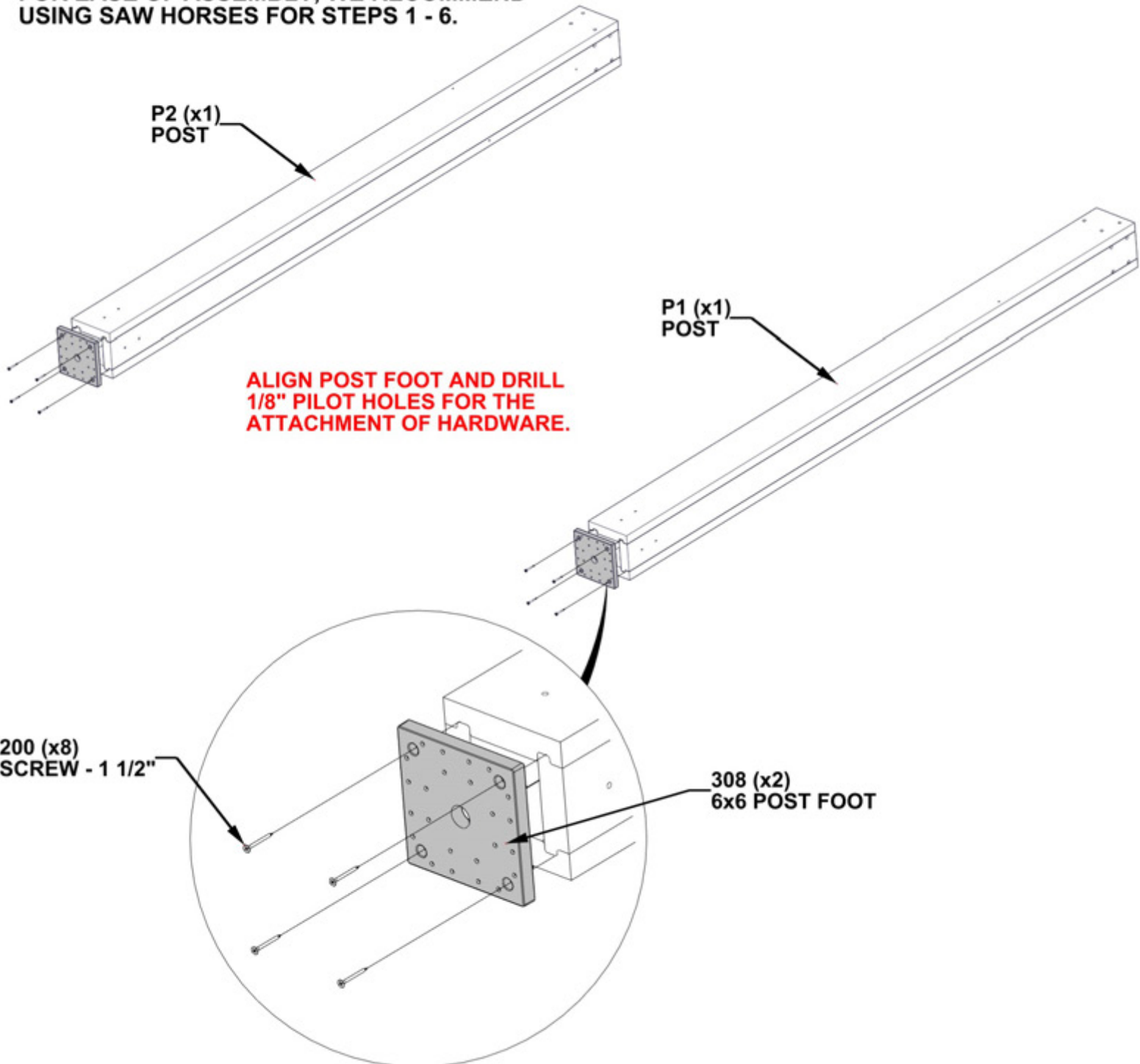

STEP 2 - GAZEBO ASSEMBLY

QTY	PART NUMBER	DESCRIPTION
4	H100483	SCREW PFH 8x2 1/4 BLK
8	H100512	BOLT WH 5/16x4 BLK
16	H100459	BOLT WH 5/16x1 1/4 BLK
24	H100192	NUT BARREL WH 5/16X7/8 BLK

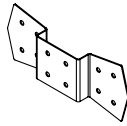
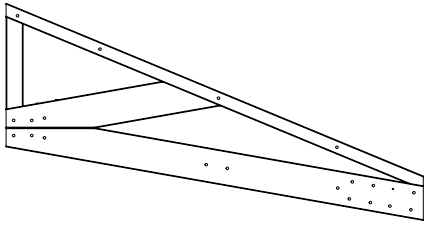

A4M01129
(x4) | GABLE BRACKET

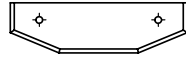

D5 | GABLE BOARD-W4L16235
(x2) | 1 7/16"x1 1/2"x5 1/4" (36x38x134)



D1 | GABLE BOARD-W4L16231
(x4) | 1 7/16"x5 1/4"x24 3/16" (36x134x615)

GT1 | GABLE TRUSS-W2A03519
(x4) | 1 7/16"x33 5/8"x64 9/16" (36x854x1640)

COMPLETE THIS STEP TWICE

IF NEEDED FOR EASE OF ASSEMBLY, USE METAL BRACKET AS A GUIDE AND DRILL THROUGH USING A 7/16" - (10mm) DRILL BIT, THEN ASSEMBLE.

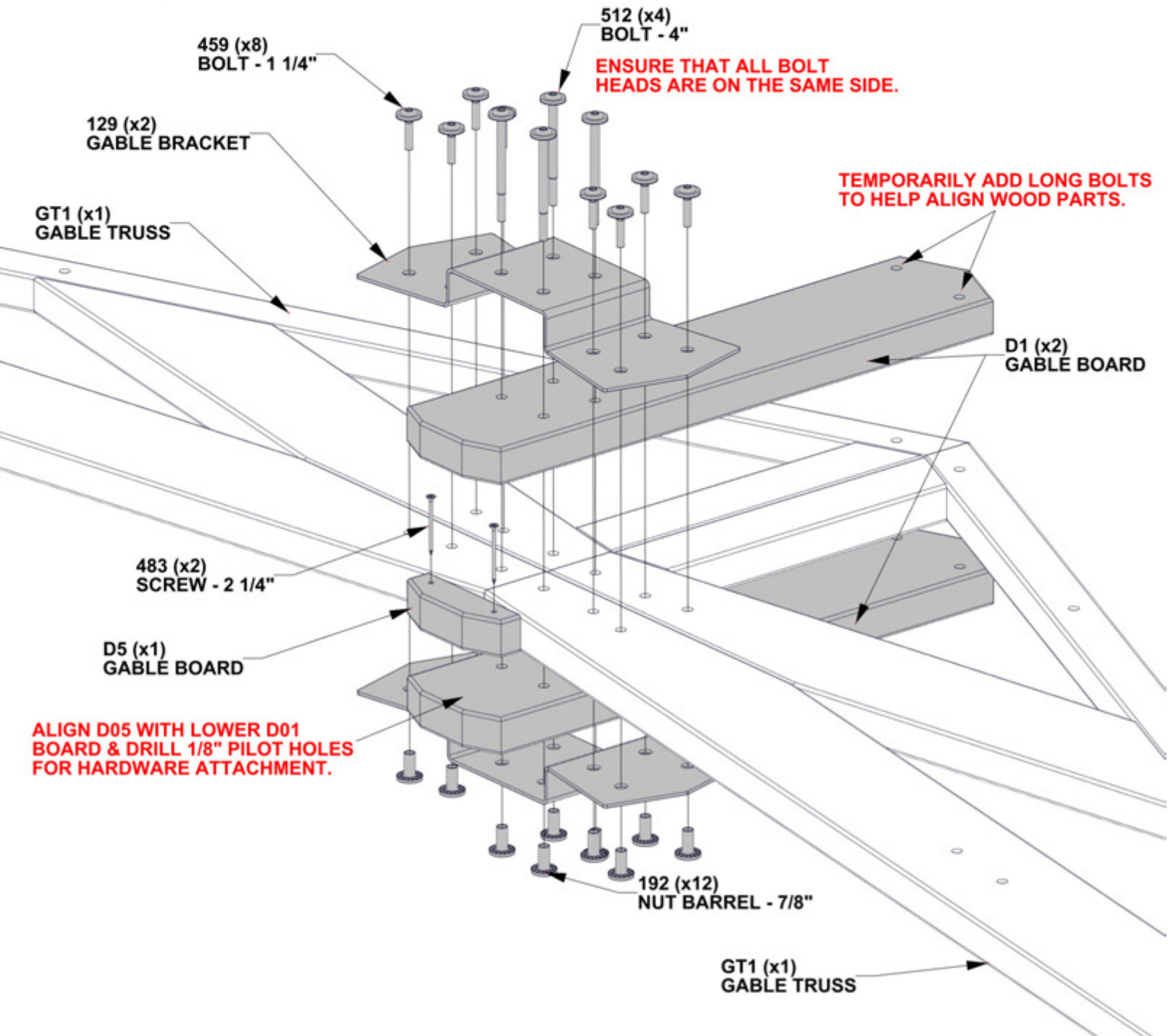

STEP 3A - GAZEBO ASSEMBLY

QTY	PART NUMBER	DESCRIPTION
8	H100471	LAG SCREW WH 5/16x1 1/2 BLK
20	H100468	BOLT WH 5/16x1 BLK
20	H100459	BOLT WH 5/16x1 1/4 BLK
28	H100354	BOLT WH 5/16x6 1/2 BLK
28	H100193	NUT BARREL WH 5/16 X 1 1/2 BLK
32	H100199	WASHER LOCK EXT 12x19
40	H100192	NUT BARREL WH 5/16X7/8 BLK

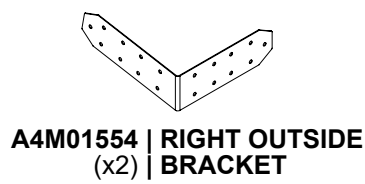
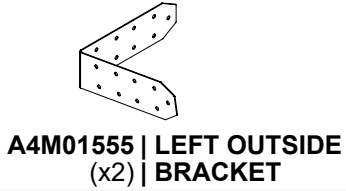
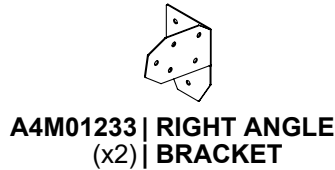
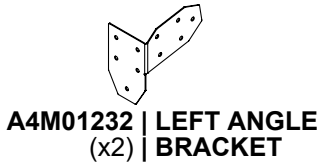

COMPLETE THIS STEP TWICE

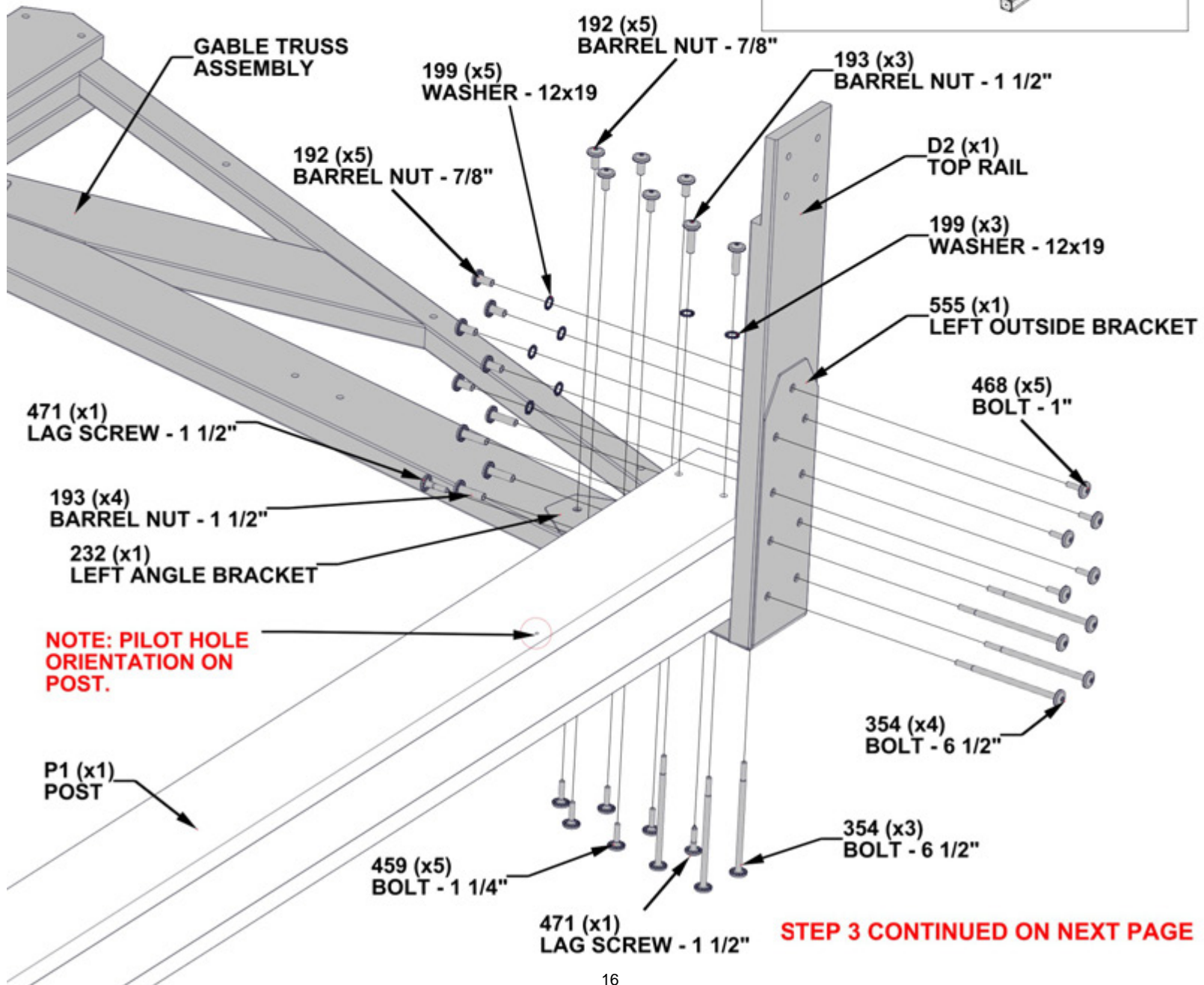
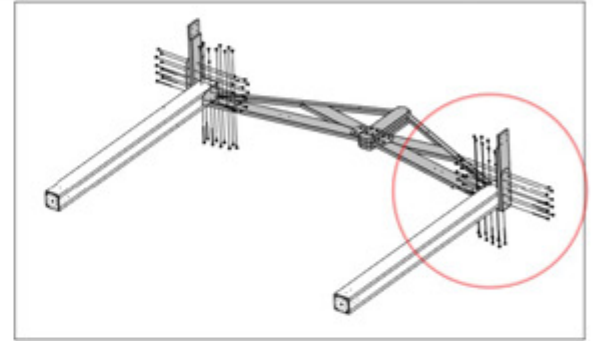

STEP 3B - GAZEBO ASSEMBLY

COMPLETE THIS STEP TWICE

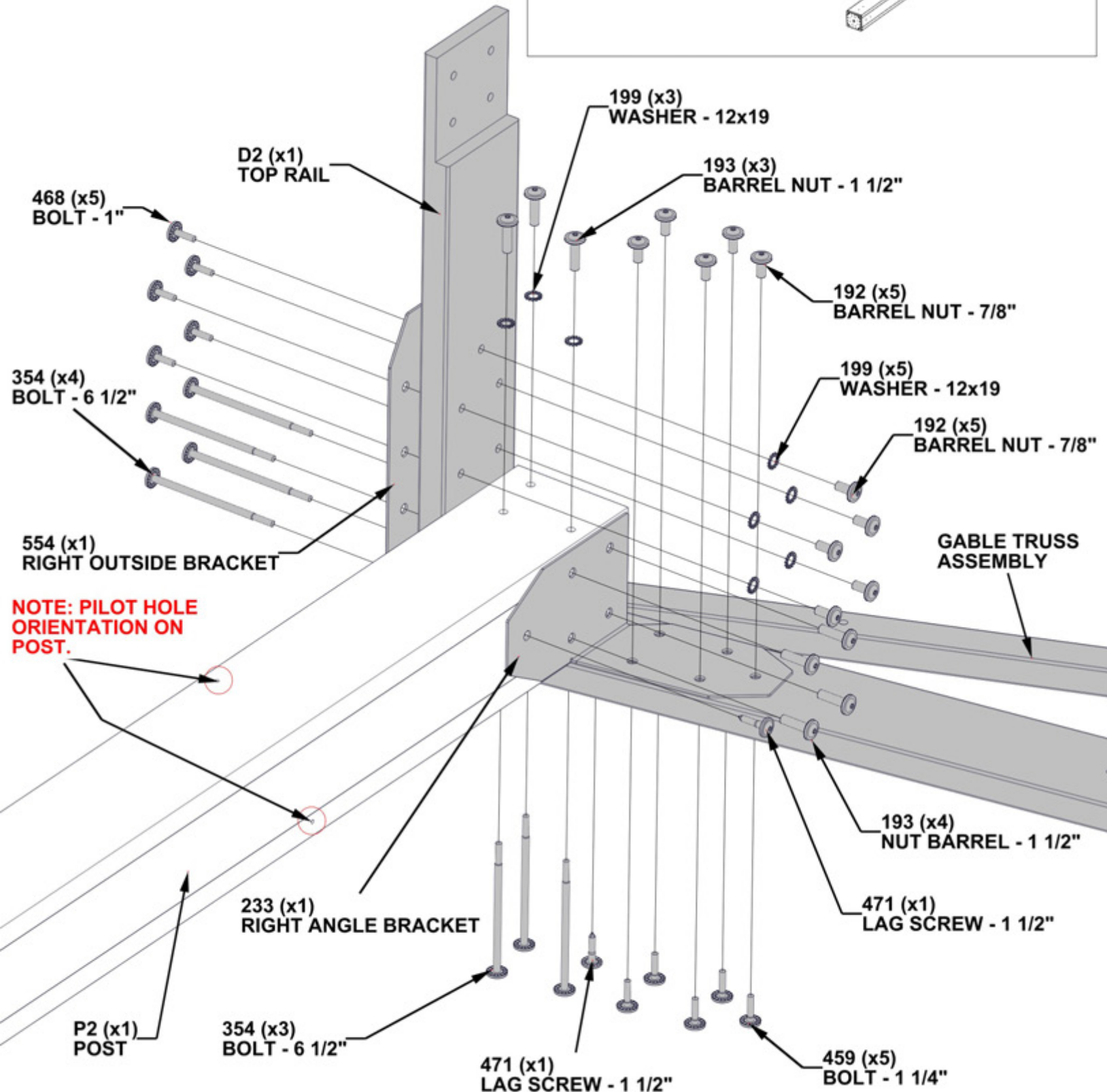
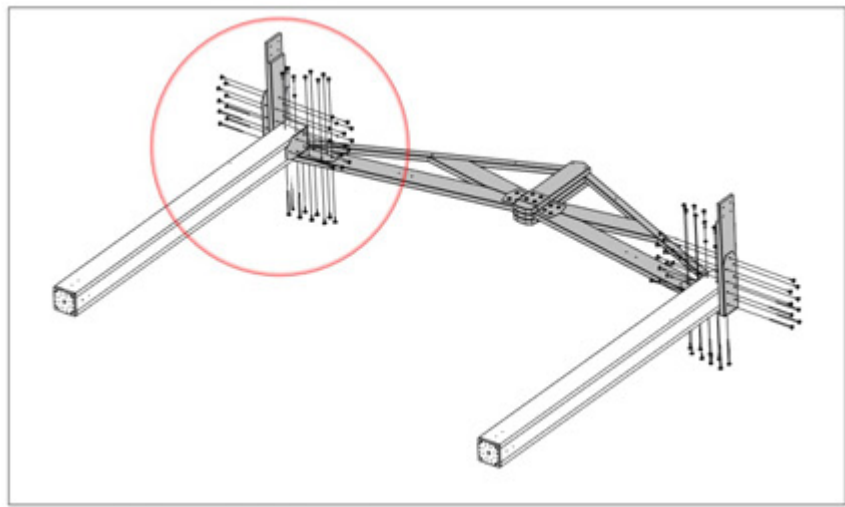

STEP 4 - GAZEBO ASSEMBLY

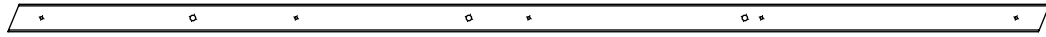

E2 | TRUSS-W4L16238
 (x4) | 1 7/16"x1 15/16"x74 15/16" (36x50x1904)

QTY	PART NUMBER	DESCRIPTION
16	H100201	SCREW PFH 8x2 1/2 BLK

COMPLETE THIS STEP TWICE

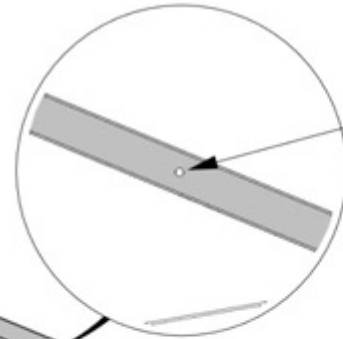

ALIGN HOLES FOR CORRECT ORIENTATION.

FLUSH TOPS

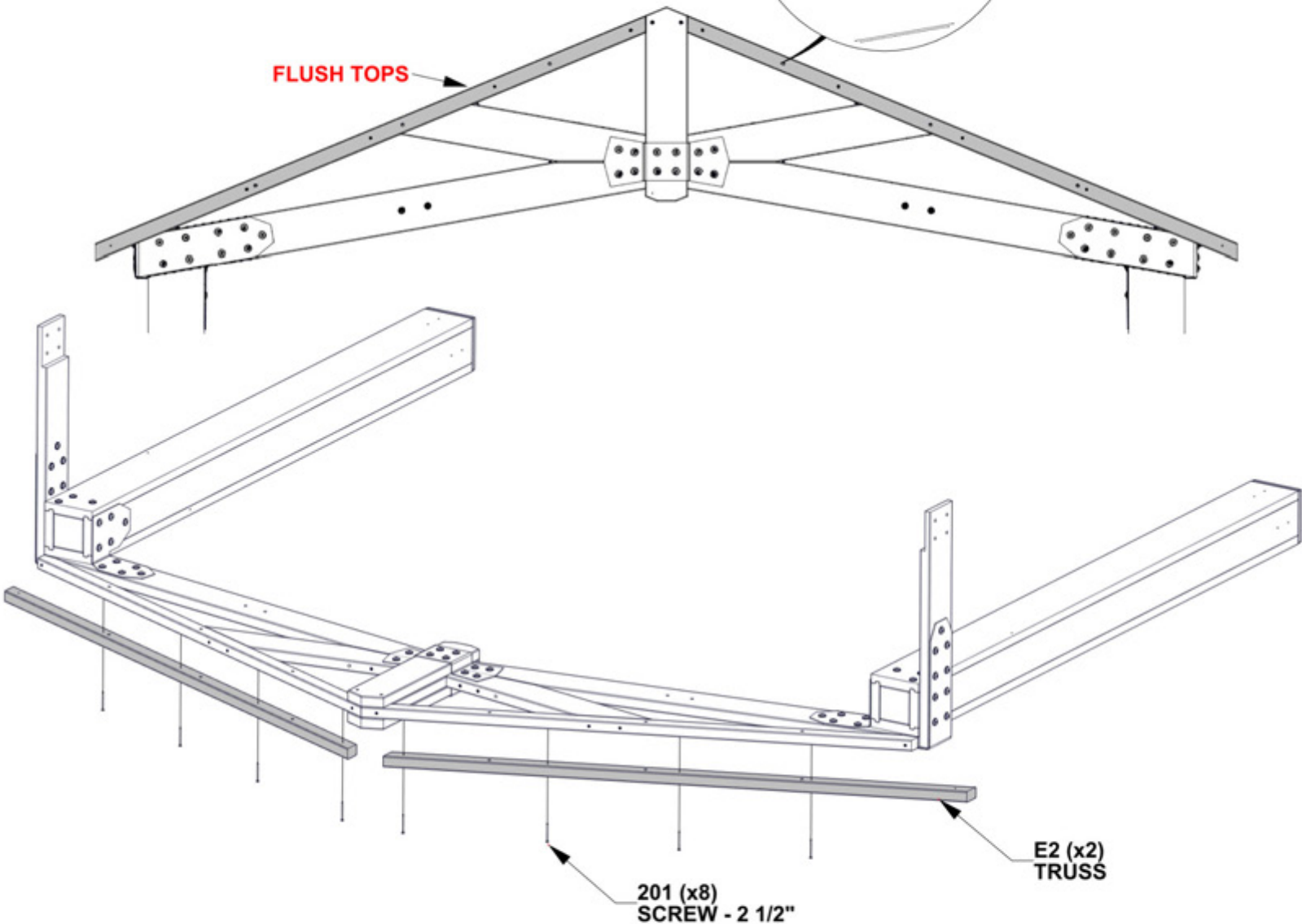

**E2 (x2)
TRUSS**

**201 (x8)
SCREW - 2 1/2"**

STEP 5 - GAZEBO ASSEMBLY



D6 | CORBEL-W4L17223
 (x4) | 1 7/16"x5 1/4"x45 7/8" (36x134x1165)

QTY	PART NUMBER	DESCRIPTION
4	H100792	LAG SCREW WH 1/4x3 BLK
4	H100405	WASHER LOCK EXT 6x15
8	H100205	BOLT WH 5/16x2 1/4 BLK
8	H100198	WASHER LOCK EXT 8x19
8	H100199	WASHER LOCK EXT 12x19
8	H100192	NUT BARREL WH 5/16X7/8 BLK

COMPLETE THIS STEP TWICE

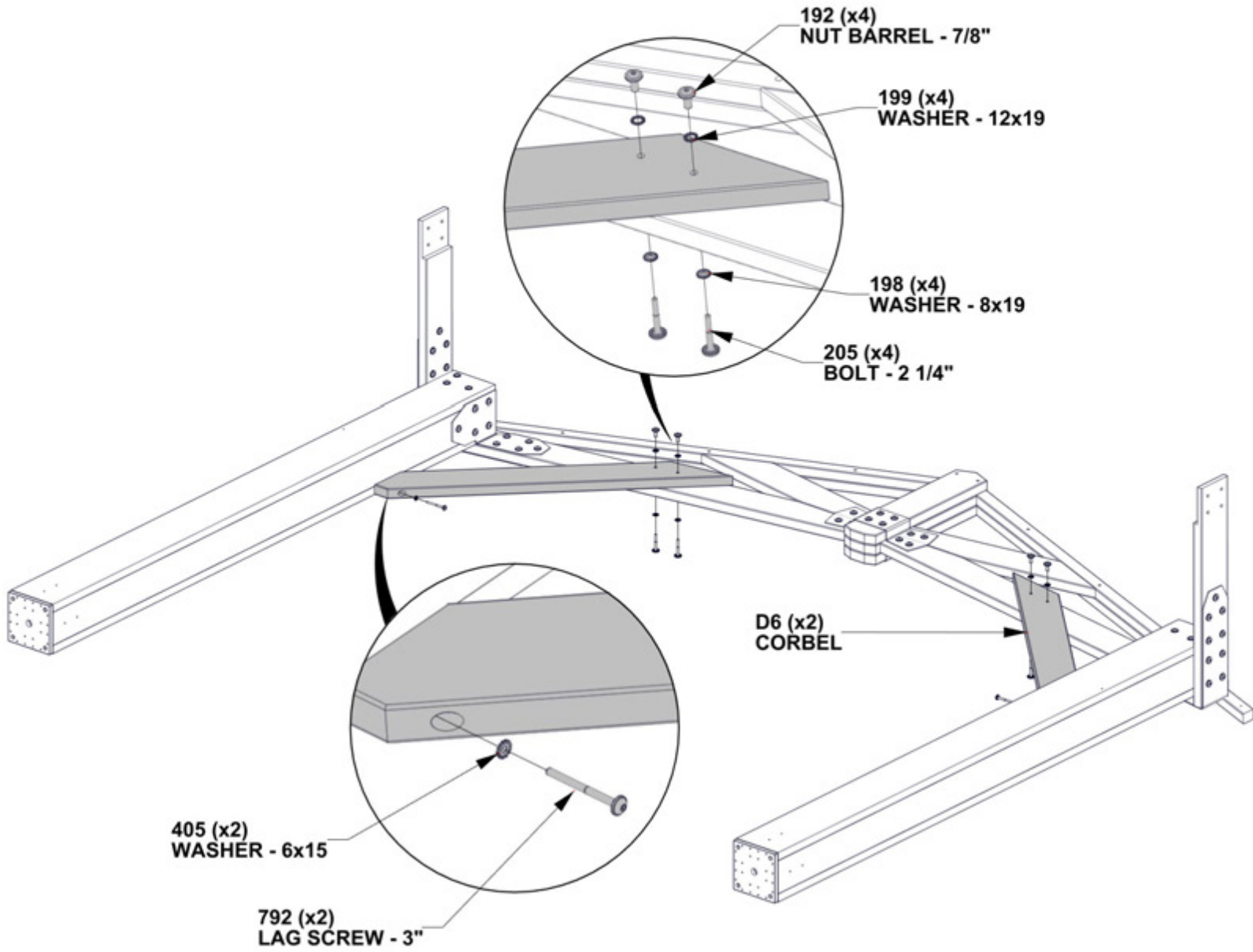

STEP 6 - GAZEBO ASSEMBLY

QTY	PART NUMBER	DESCRIPTION
4	H100200	SCREW PFH 8x1 1/2 BLK
4	H100201	SCREW PFH 8x2 1/2 BLK
8	H100471	LAG SCREW WH 5/16x1 1/2 BLK
12	H100564	LAG SCREW WH 1/4x4 BLK
12	H100405	WASHER LOCK EXT 6x15

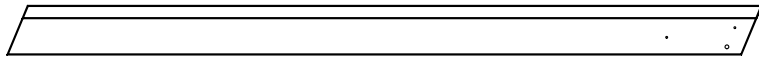

GP1 | GABLE PANEL-W2A03379
(x2) | 2 13/16"x5 1/4"x80 3/16" (72x134x2037)

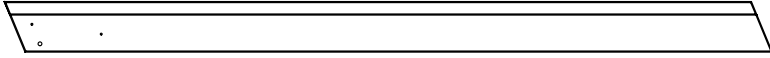

GP2 | GABLE PANEL-W2A03380
(x2) | 2 13/16"x5 1/4"x80 3/16" (72x134x2037)

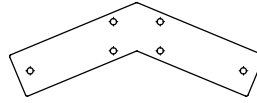

A4M01130 | GABLE BRACKET
(x2)



A4M01147 | PEAK SEAM BRACKET
(x2)

COMPLETE THIS STEP TWICE

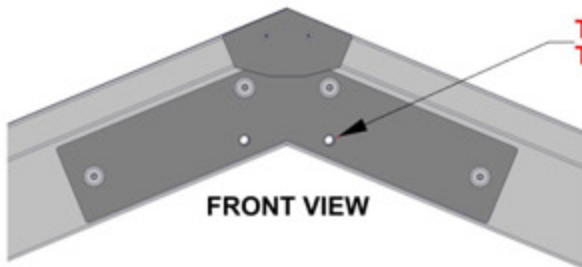

TEMPORARILY ADD LONG BOLTS TO HELP ALIGN WOOD PARTS.

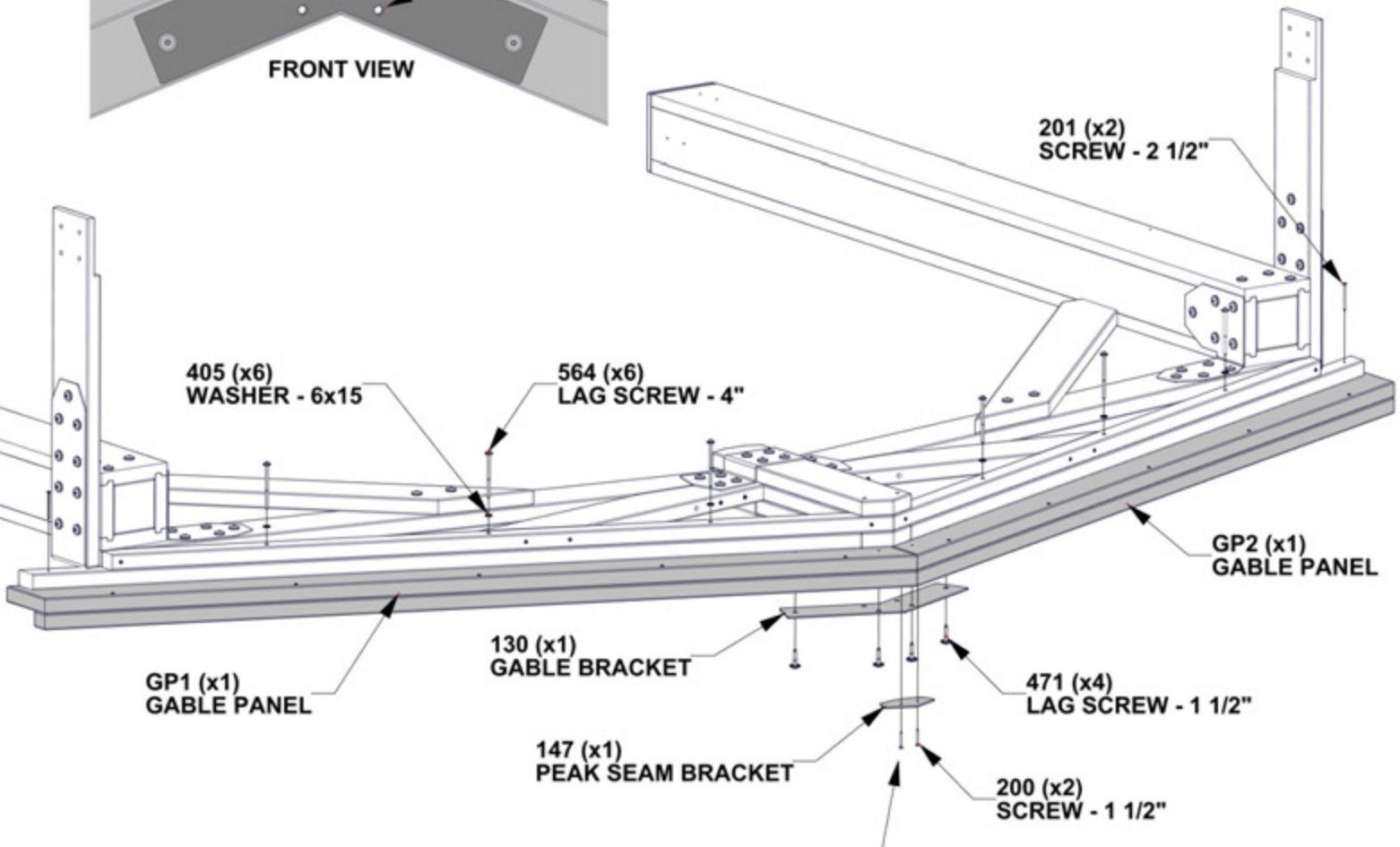

PRE-DRILL PILOT HOLES FOR SCREWS USING PEAK SEAM AS A GUIDE.

STEP 7 - GAZEBO ASSEMBLY



D3 | TOP RAIL-W4L17222
 (x2) | 1 7/16"x5 1/4"x64 5/16" (36x134x1634)

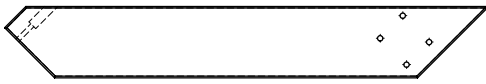

D4 | CORBEL-W4L16234
 (x2) | 1 7/16"x5 1/4"x35 7/8" (36x134x910)

QTY	PART NUMBER	DESCRIPTION
2	H100792	LAG SCREW WH 1/4x3 BLK
2	H100405	WASHER LOCK EXT 6x15
8	H100205	BOLT WH 5/16x2 1/4 BLK
8	H100198	WASHER LOCK EXT 8x19
8	H100192	NUT BARREL WH 5/16X7/8 BLK
8	H100199	WASHER LOCK EXT 12x19

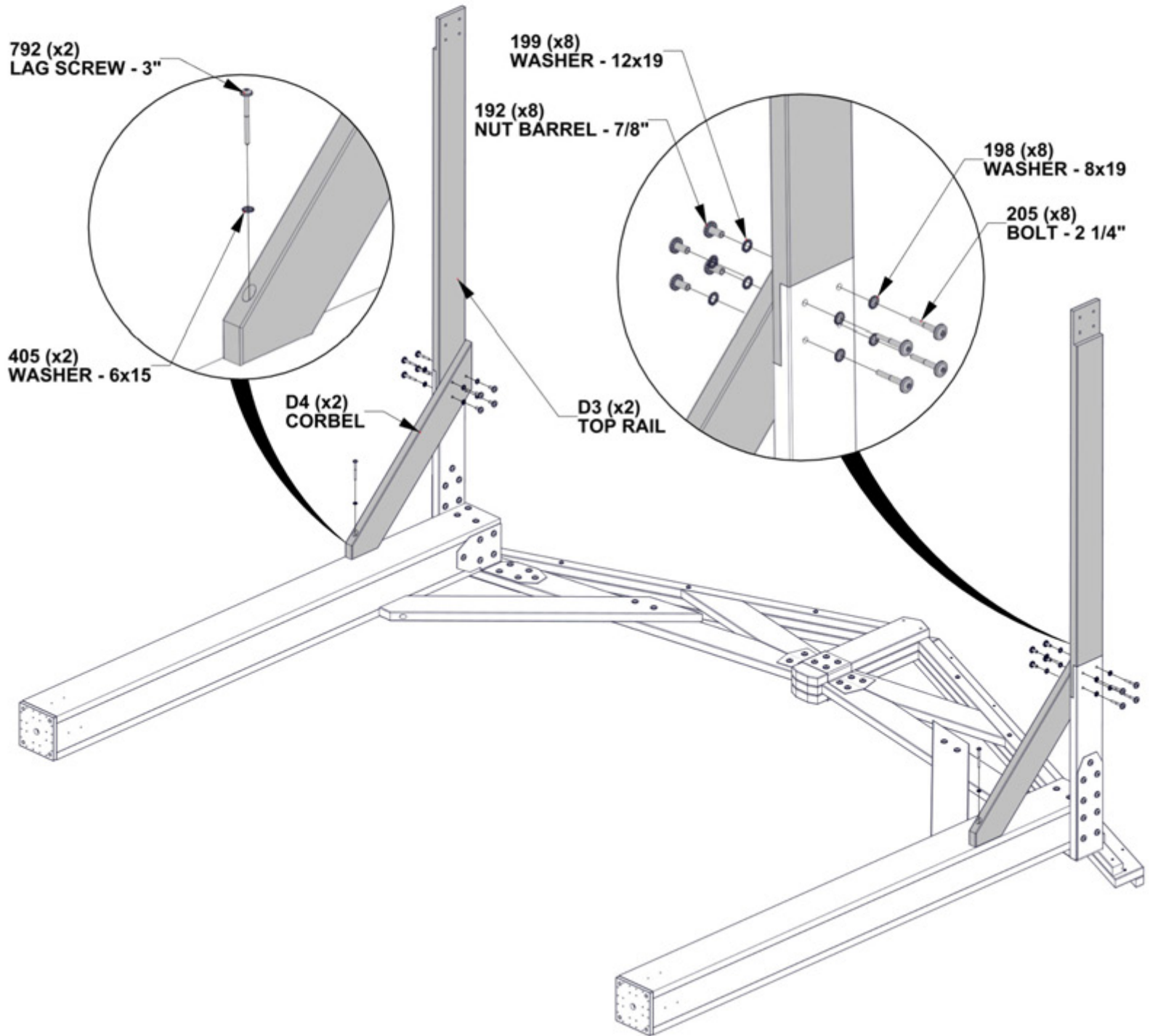

STEP 8 - GAZEBO ASSEMBLY



D4 | CORBEL-W4L16234
 (x1) | 1 7/16"x5 1/4"x35 7/8" (36x134x910)



D7 | CORBEL W/TAG-W2A03384
 (x1) | 1 7/16"x5 1/4"x35 13/16" (36x134x910)

QTY	PART NUMBER	DESCRIPTION
2	H100792	LAG SCREW WH 1/4x3 BLK
2	H100405	WASHER LOCK EXT 6x15
8	H100192	NUT BARREL WH 5/16X7/8 BLK
8	H100199	WASHER LOCK EXT 12x19
8	H100205	BOLT WH 5/16x2 1/4 BLK
8	H100198	WASHER LOCK EXT 8x19

FOR THIS STEP IT IS HELPFUL TO HAVE THREE ADDITIONAL PEOPLE TO HELP STAND UP ASSEMBLY AND ATTACH HARDWARE.

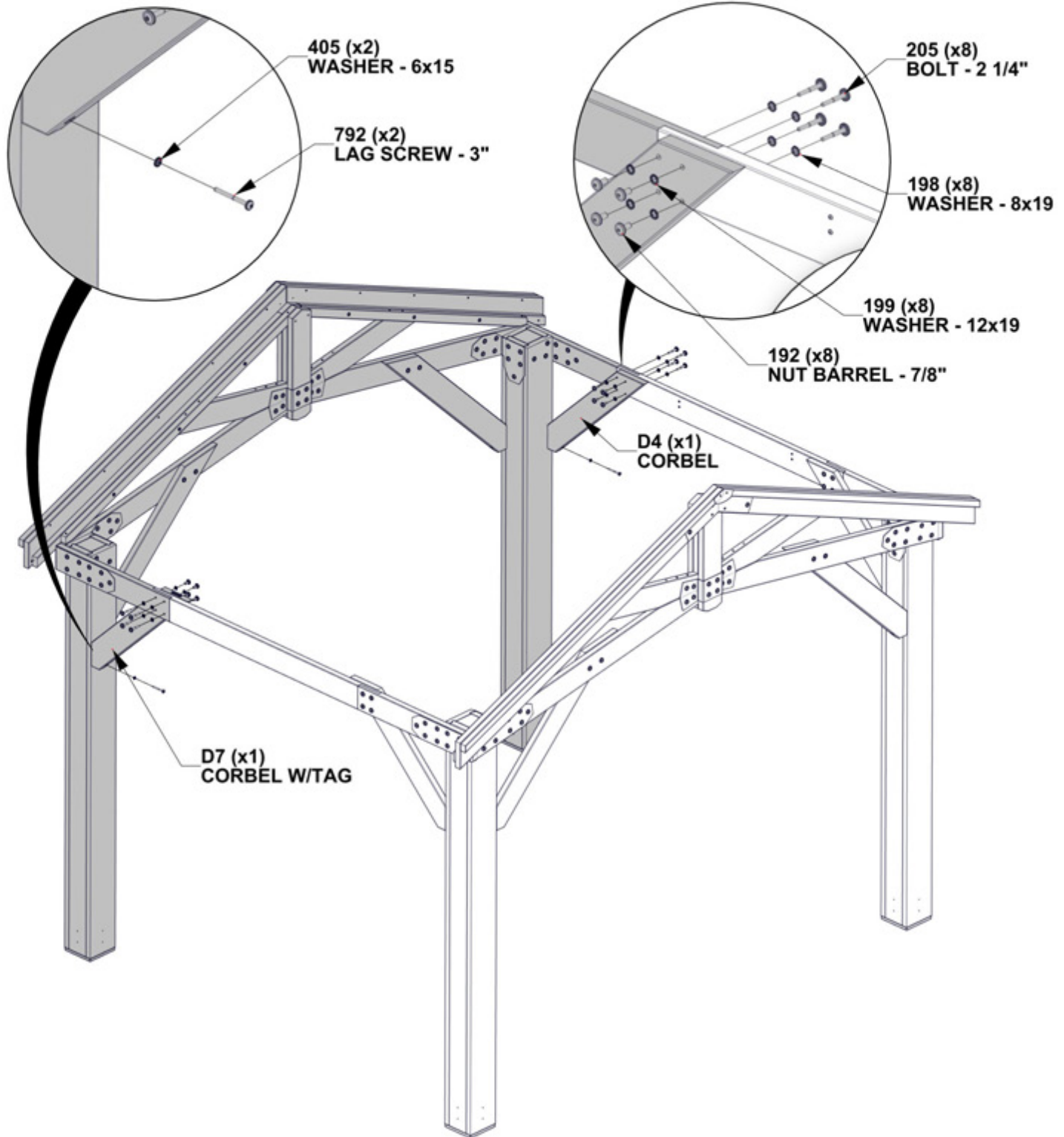

STEP 9 - GAZEBO ASSEMBLY

QTY	PART NUMBER	DESCRIPTION
8	H100200	SCREW PFH 8x1 1/2 BLK
24	H100391	SCREW PFH 8x2 BLK

E1 | RAFTER-W4L16237
 (x8) | 1 7/16"x3 3/8"x77 3/8" (36x86x1965)

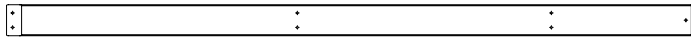

H2 | FASCIA-W4L16241
 (x2) | 15/16"x3 3/8"x74 11/16" (24x86x1896)



H5 | RAFTER-W4L16244
 (x2) | 15/16"x3 3/8"x70 7/16" (24x86x1789)

H4 | RAFTER-W4L16243
 (x2) | 15/16"x3 3/8"x39 13/16" (24x86x1011)

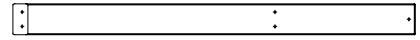

H3 | FASCIA-W4L16242
 (x2) | 15/16"x3 3/8"x44" (24x86x1118)

COMPLETE THIS STEP TWICE

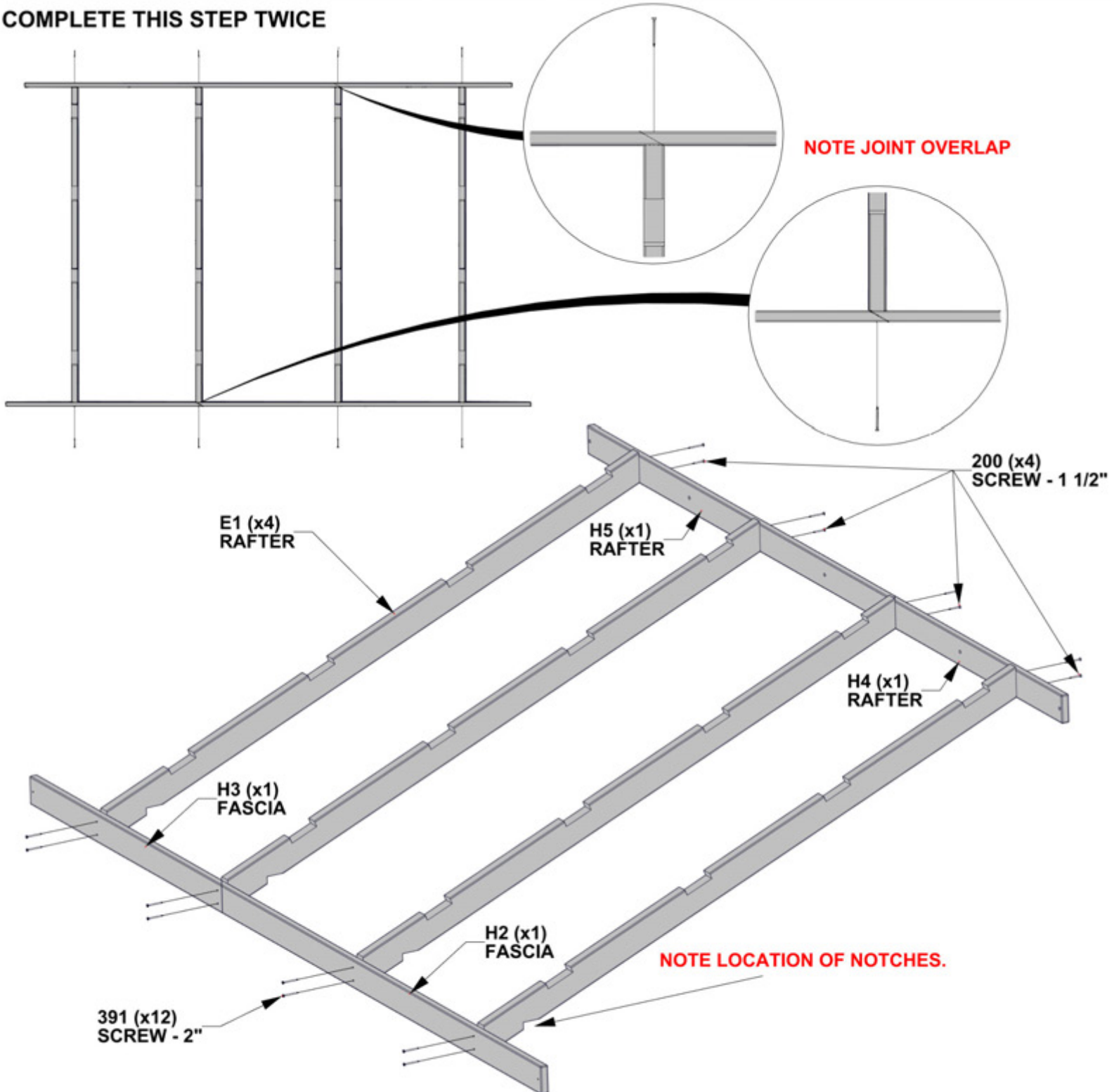

STEP 10 - GAZEBO ASSEMBLY



E3 | SHEATHING BOARD-W4L16239
(x8) | 1 7/16"x3 3/8"x73 1/4" (36x86x1861)



E4 | SHEATHING BOARD-W4L16240
(x8) | 1 7/16"x3 3/8"x45 3/4" (36x86x1161)

QTY	PART NUMBER	DESCRIPTION
16	H100379	T-NUT 5/16" BLK
16	H100198	WASHER LOCK EXT 8x19
16	H100459	BOLT WH 5/16x1 1/4 BLK
32	H100391	SCREW PFH 8x2 BLK

COMPLETE THIS STEP TWICE

MEASURE ON THE DIAGONAL AS SHOWN TO ENSURE THAT ASSEMBLY IS SQUARE.

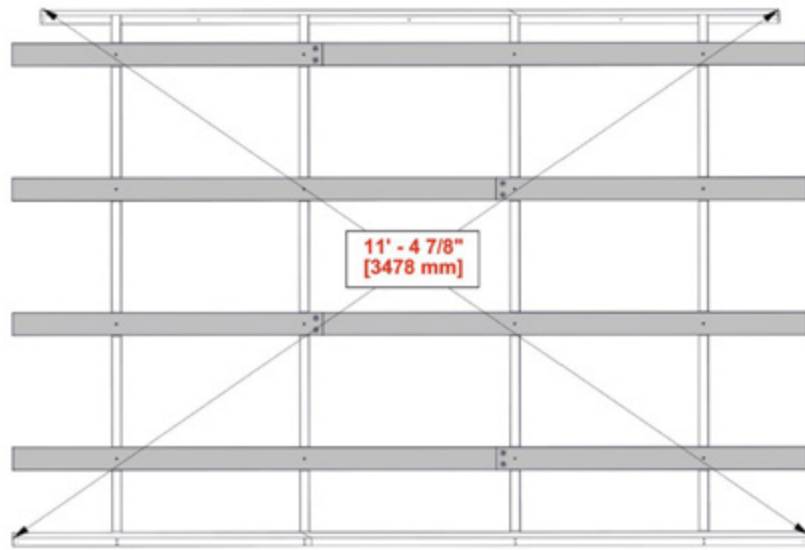

**E4 (x1)
SHEATHING
BOARD**

**E3 (x1)
SHEATHING
BOARD**

**E4 (x1)
SHEATHING
BOARD**

**E3 (x1)
SHEATHING
BOARD**

**E3 (x1)
SHEATHING
BOARD**

**E4 (x1)
SHEATHING
BOARD**

**E3 (x1)
SHEATHING
BOARD**

**E4 (x1)
SHEATHING
BOARD**

**459 (x8)
BOLT - 1 1/4"**

**391 (x16)
SCREW - 2"**

**379 (x8)
T-NUT - 5/16"**

**198 (x8)
WASHER - 8x19**

STEP 11 - GAZEBO ASSEMBLY

NOTE:
USE THIS PAGE TO FAMILIARIZE YOURSELF WITH THE ROOF PANEL & ASSIST YOU IN THE COMING STEPS.

WARNING:
GLOVES SHOULD BE WORN WHEN HANDLING ROOF PANELS; EDGES ARE SHARP.

- Note the pre-drilled holes on the top end of each sheet shown below. These holes will always go towards the ridge of the roof and will be used to install the ridge cap in a later step. Assemble each roof panel by starting on the right side and working toward the left as shown.

POSITION YOUR ROOF PANELS ON THE GROUND SO THEY MIRROR EACH OTHER AS SHOWN. REMOVE PROTECTIVE BLUE FILM FROM PANELS.

STARTING EDGE OF ROOF SHEETING FLARES UP AS SHOWN.

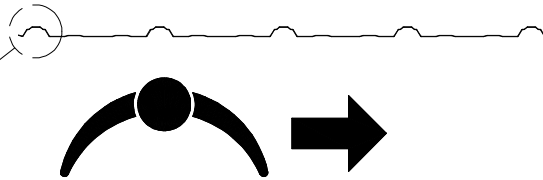
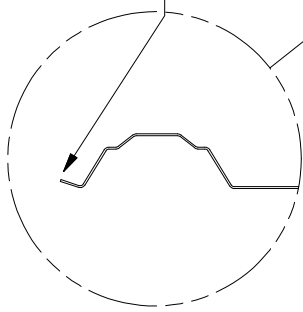

TOP VIEW

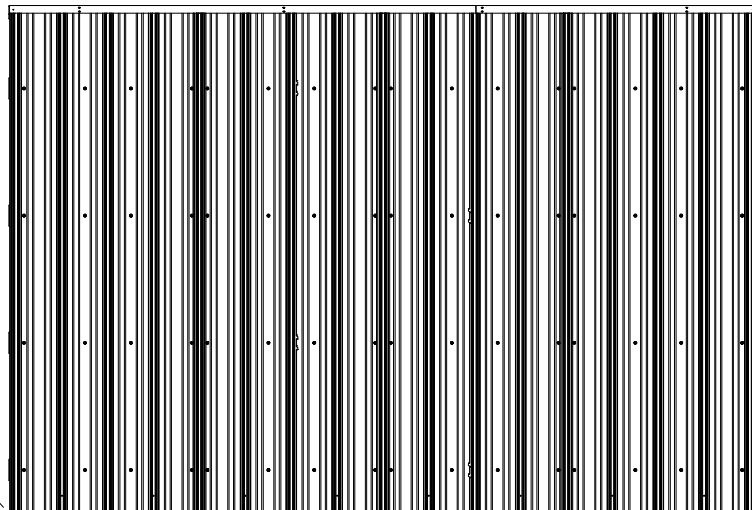

RIDGE

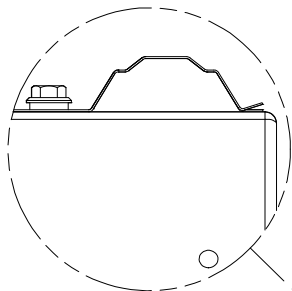

STARTING EDGE INSTALLED

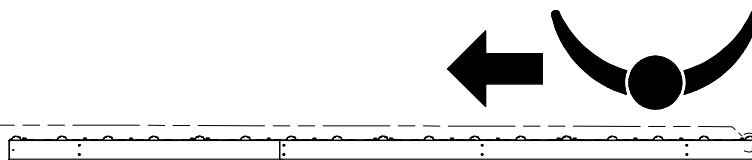

STEP 12 - GAZEBO ASSEMBLY



A4M01124
(x2) 29 GA STEEL SHEETING

QTY	PART NUMBER	DESCRIPTION
8	H100760	SCREW WOODGRIP 10x1-1/4

MAKE SURE YOUR ROOF PANEL IS SQUARE BEFORE MOVING ON.

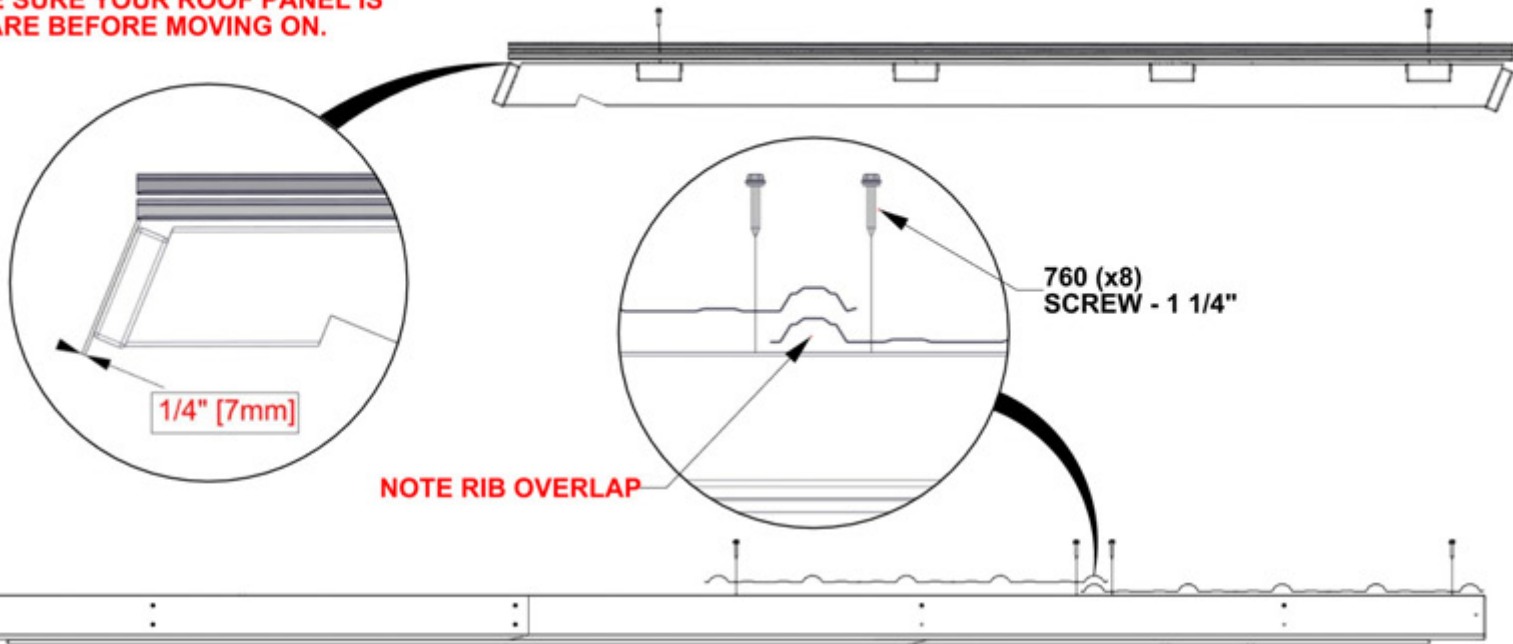

NOTE RIB OVERLAP

NOTE THRU HOLES

124 (x2)
29 GA STEEL SHEETING

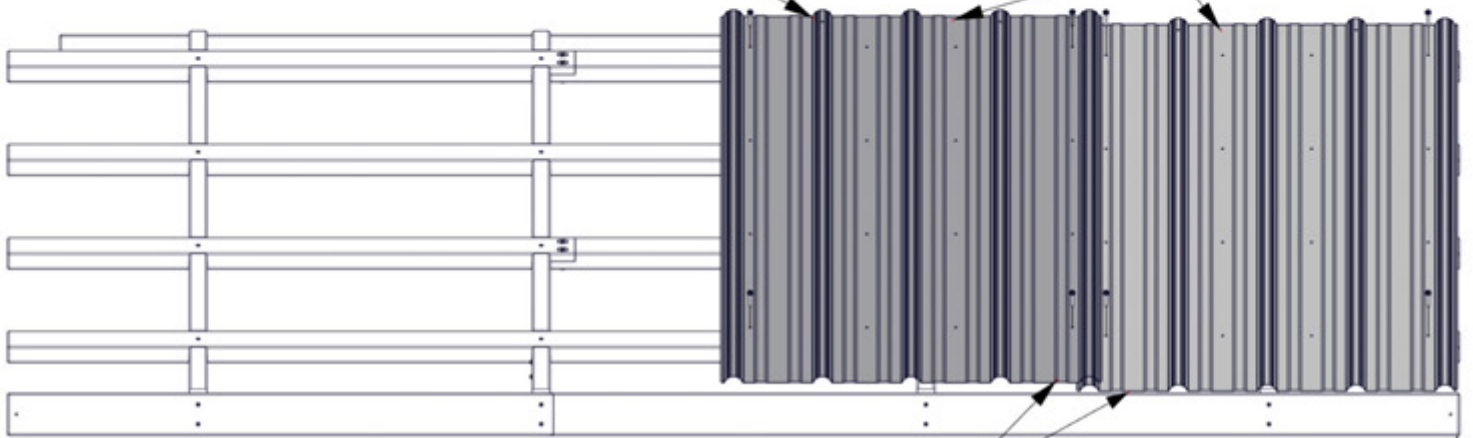

FLUSH SHEETING ENDS

HOLD SHEETING INSIDE OF FRAME MEASURING FROM RIB AS SHOWN.

1/8" [4mm]

STEP 13 - GAZEBO ASSEMBLY

QTY	PART NUMBER	DESCRIPTION
24	H100760	SCREW WOODGRIP 10x1-1/4

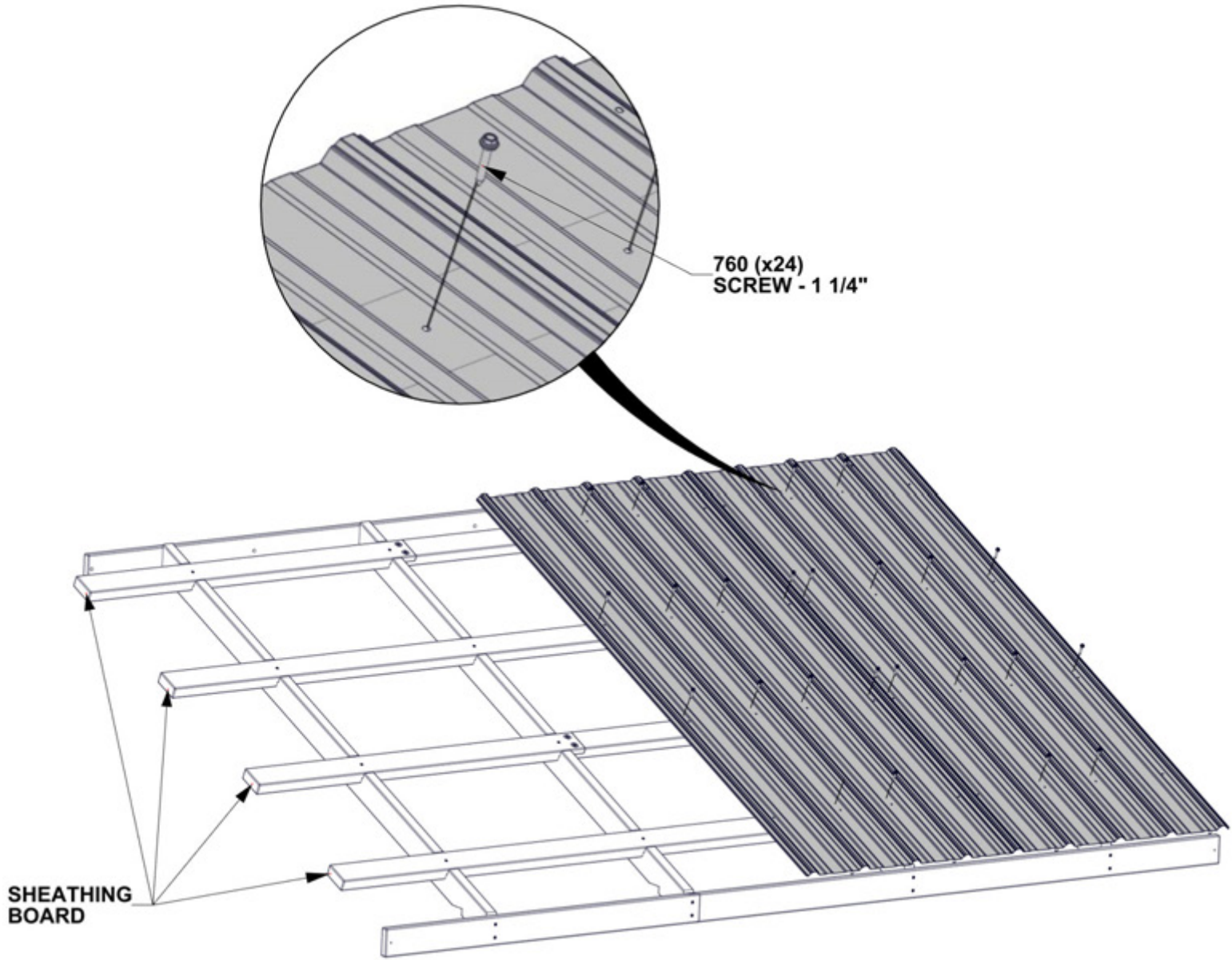

STEP 14 - GAZEBO ASSEMBLY



A4M01124
(x2) 29 GA STEEL SHEETING

QTY	PART NUMBER	DESCRIPTION
32	H100760	SCREW WOODGRIP 10x1-1/4

REPEAT STEPS 12 THROUGH 14 FOR THE OTHER SIDE

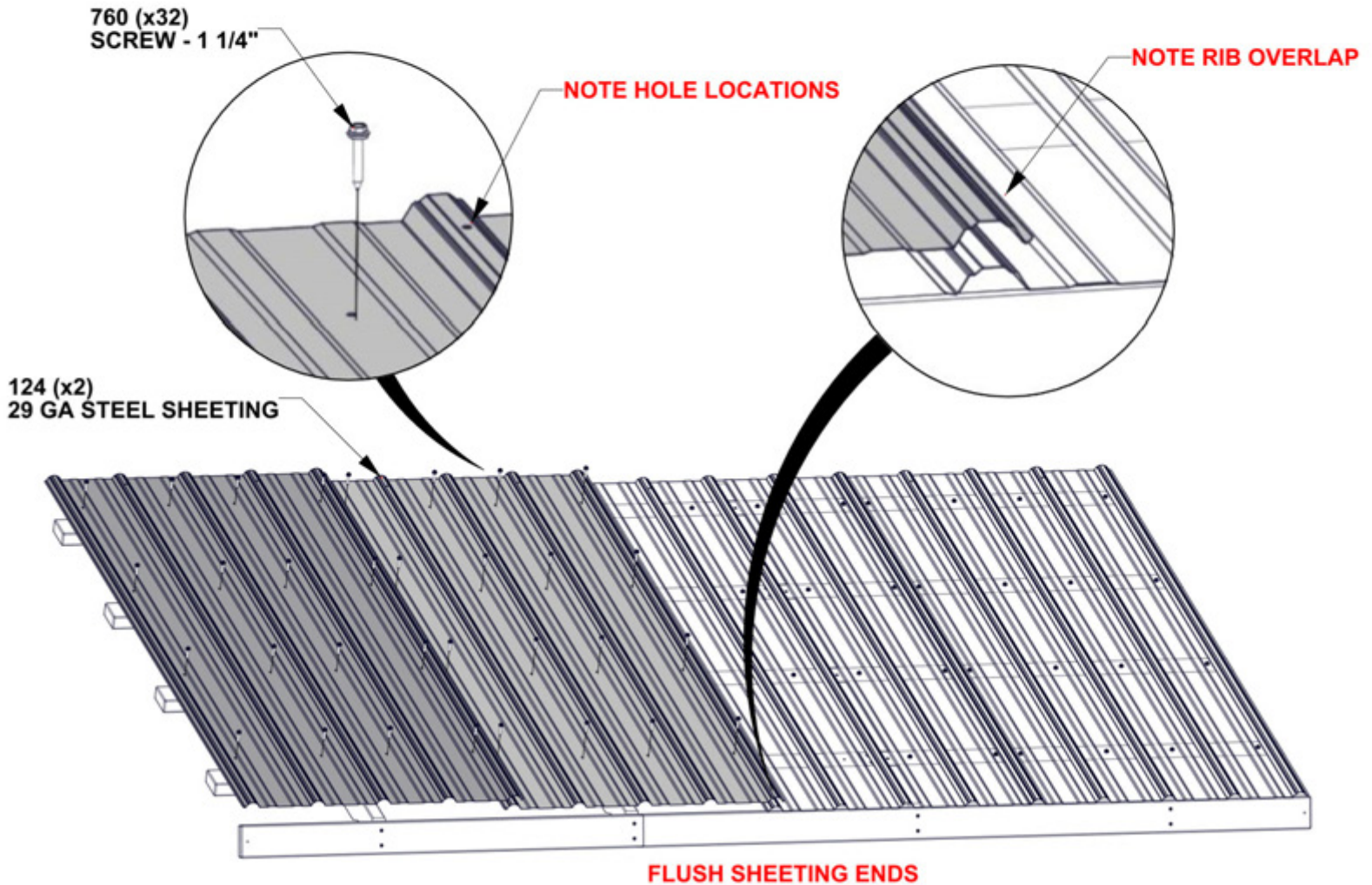

STEP 15 - GAZEBO ASSEMBLY

A4M00983
(x2)  ROOF EDGE TRIM SPLICE

QTY	PART NUMBER	DESCRIPTION
16	H100759	SCREW TAPPING 1/4x3/4

A4M00982
(x4) ROOF EDGE TRIM

REPEAT STEP FOR OTHER ROOF PANEL

DUE TO MULTIPLE LAYERS OF METAL ON THE EDGE TRIM, IT IS RECOMMENDED THAT A 1/8" DRILL BIT IS USED TO CREATE STARTER HOLES.

SCREWS GO THOROUGH EDGE TRIM INTO THE TOP OF THE RIBS IN THE APPROXIMATE LOCATIONS SHOWN.

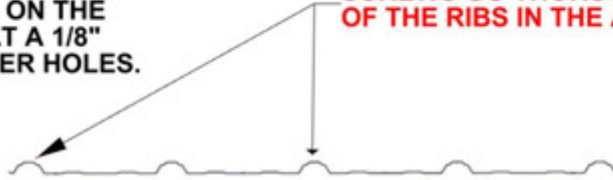

SLIDE EDGE TRIM INTO SPLICE.
ENSURE THAT BOTH ENDS ARE FLUSH
WITH EDGE OF ROOF PANELS.

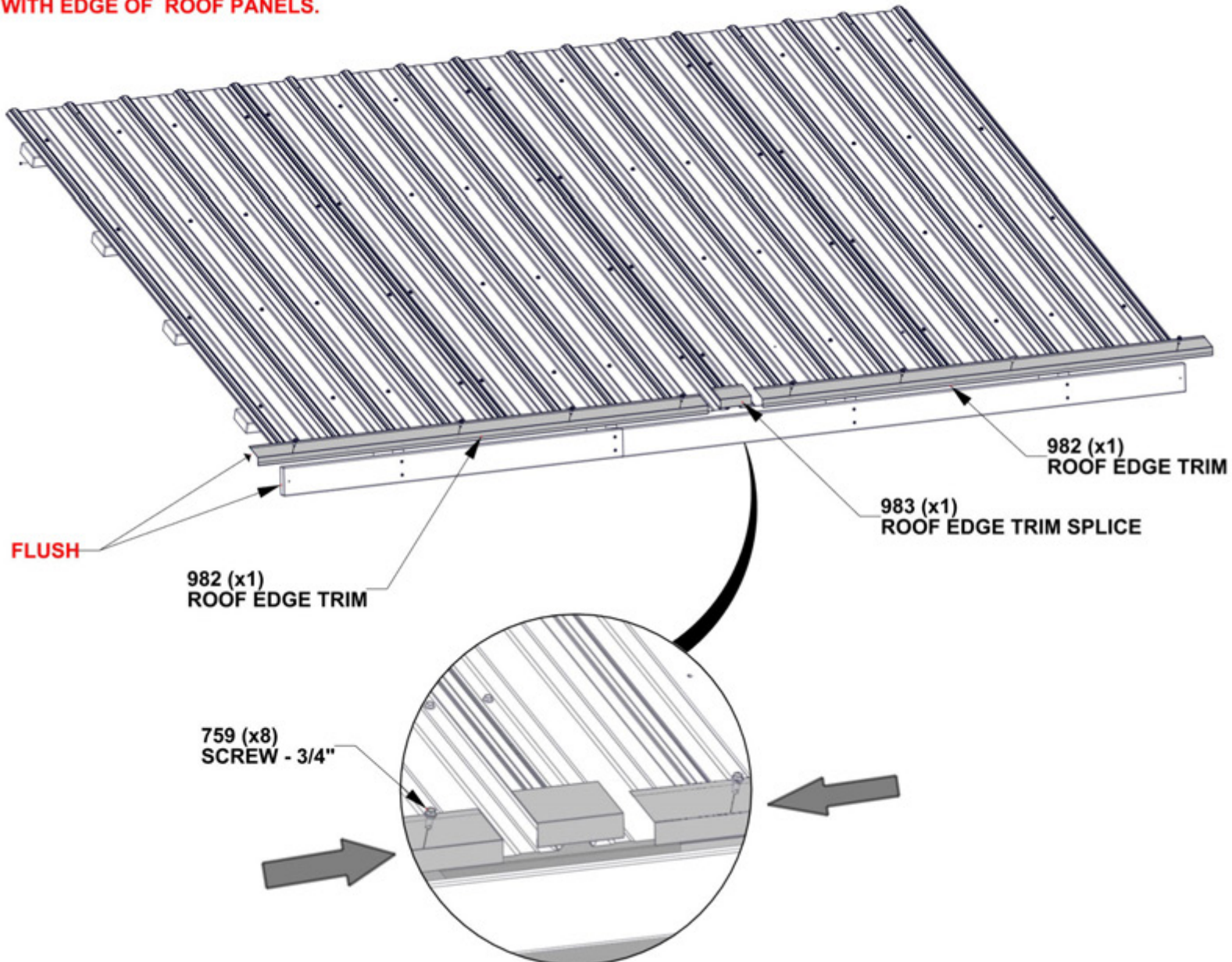

STEP 16 - GAZEBO ASSEMBLY

QTY	PART NUMBER	DESCRIPTION
4	H100391	SCREW PFH 8x2 BLK

COMPLETE THIS STEP TWICE

WITH AT LEAST TWO PEOPLE, LIFT ASSEMBLED ROOF PANEL AND SLIDE IT INTO THE TRACKS ON THE RAFTERS. ONCE IN PLACE, INSTALL ATTACHMENT HARDWARE AS SHOWN.

A THIRD PERSON IS HELPFUL TO ATTACH ROOF ONCE IT IS IN PLACE.

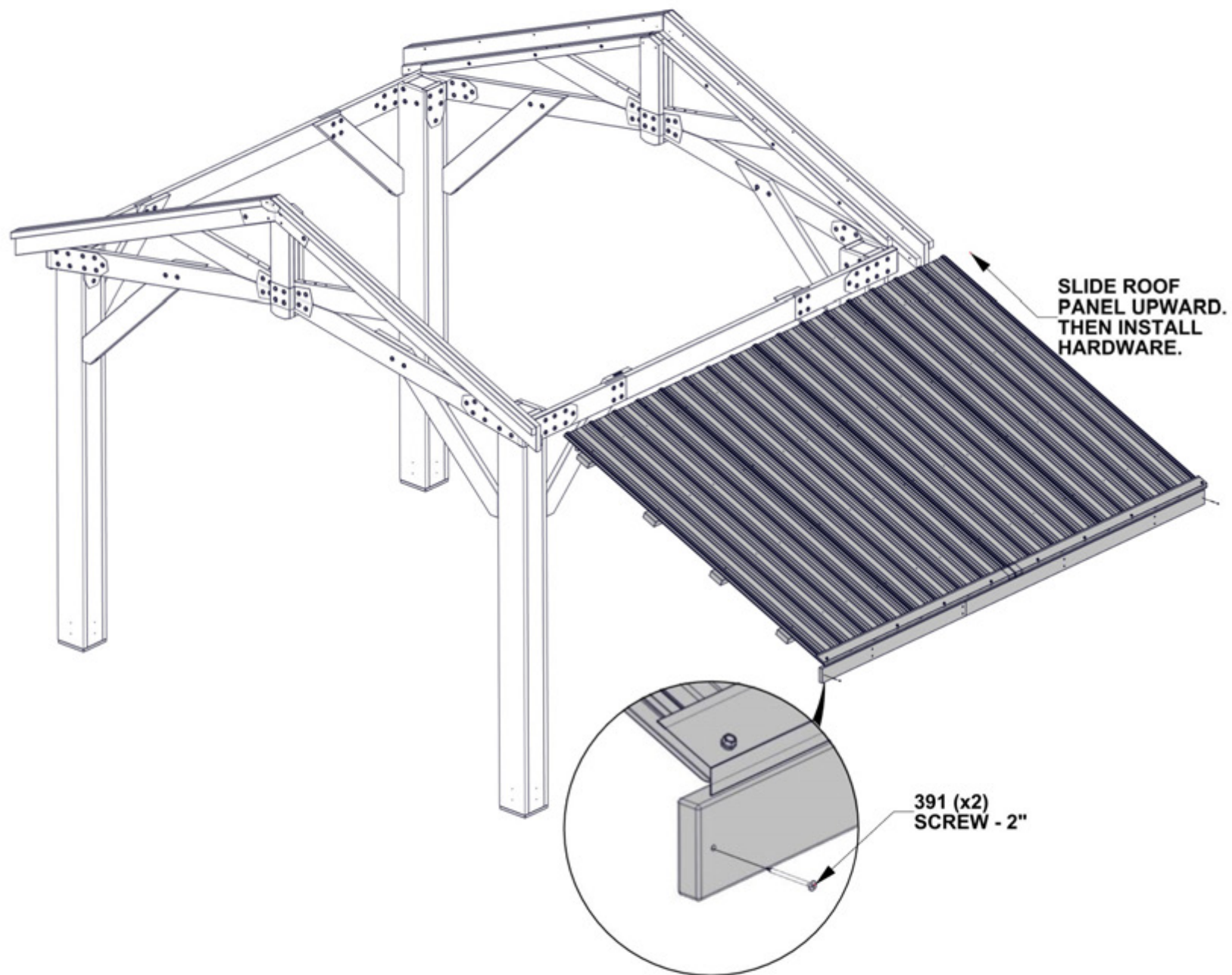

STEP 17 - GAZEBO ASSEMBLY

QTY	PART NUMBER	DESCRIPTION
3	H100407	BOLT WH 5/16x1 1/2 BLK
3	H100198	WASHER LOCK EXT 8x19
3	H100199	WASHER LOCK EXT 12x19
3	H100192	NUT BARREL WH 5/16X7/8 BLK

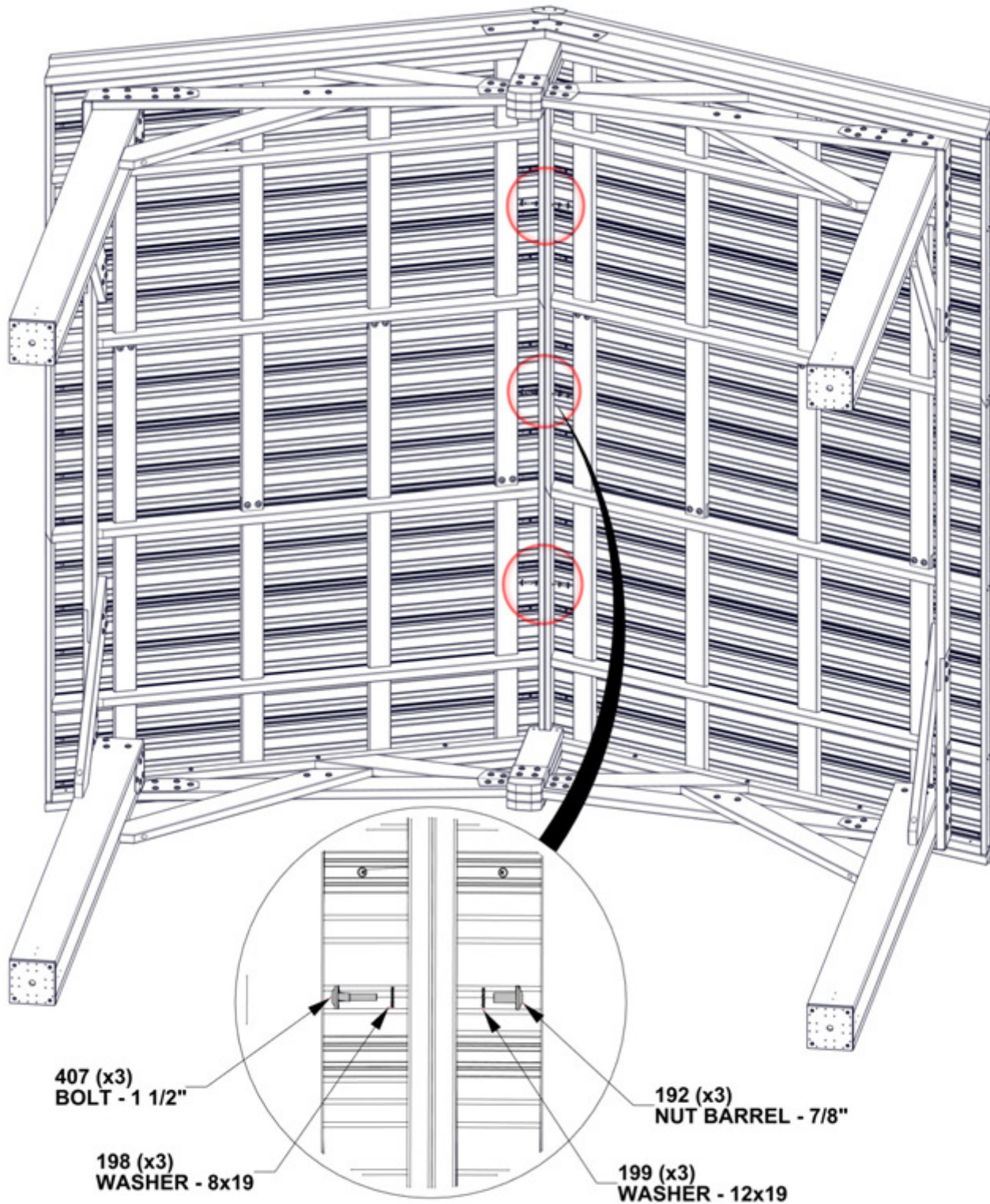

STEP 18 - GAZEBO ASSEMBLY

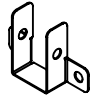

A4M01148
(x2) | **TRUSS BRACKET**

QTY	PART NUMBER	DESCRIPTION
2	H100378	BOLT WH 5/16x1 3/4 BLK
2	H100192	NUT BARREL WH 5/16X7/8 BLK
4	H100354	BOLT WH 5/16x6 1/2 BLK
4	H100770	WASHER FLAT 9.5x22 BLK
4	H100479	NUT LOCK 5/16 BLK

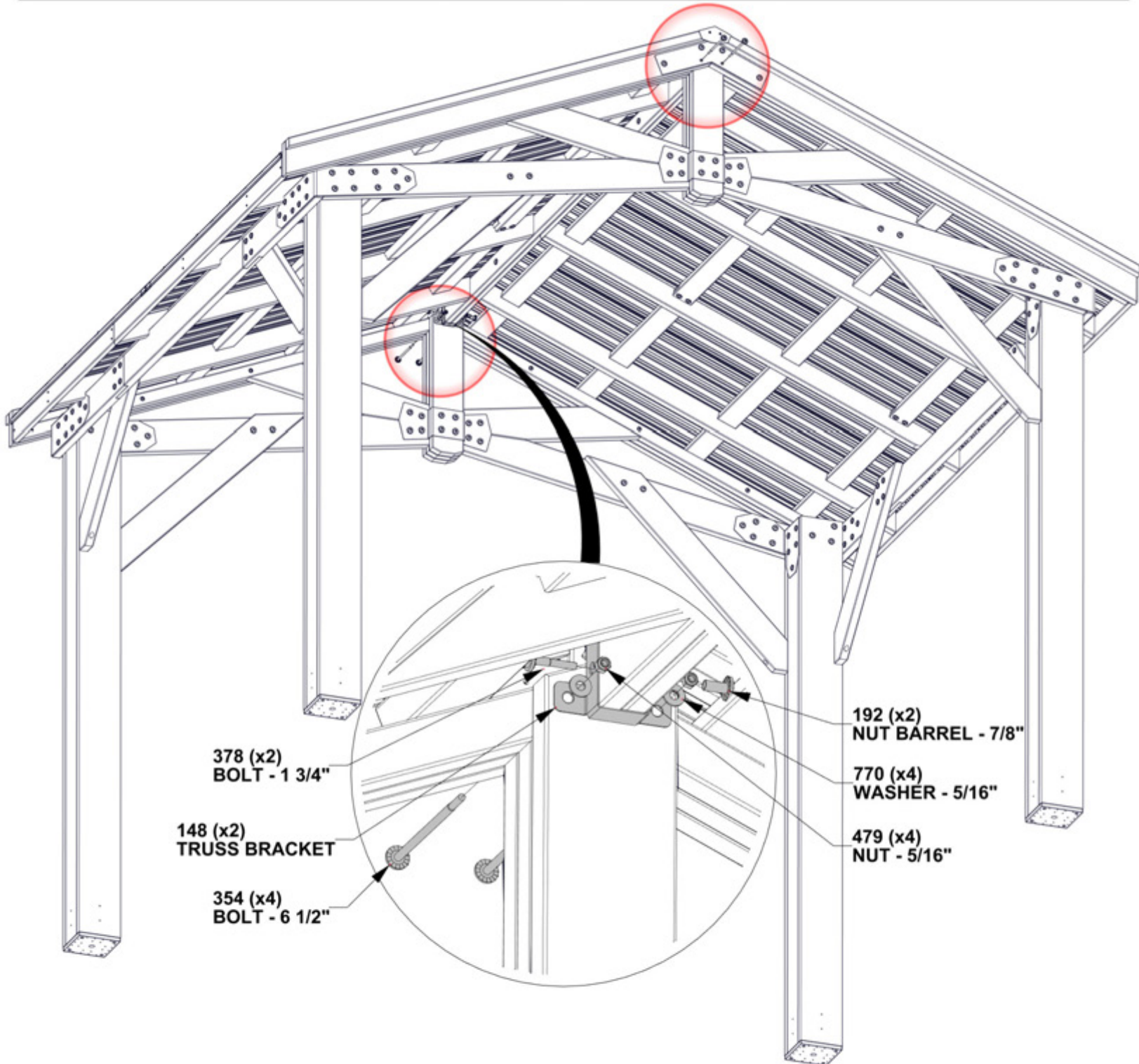

STEP 19 - GAZEBO ASSEMBLY

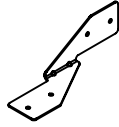

A4M01155 | TIE BRACKET
(x4)

QTY	PART NUMBER	DESCRIPTION
16	H100797	SCREW PWH 8x1 BLK

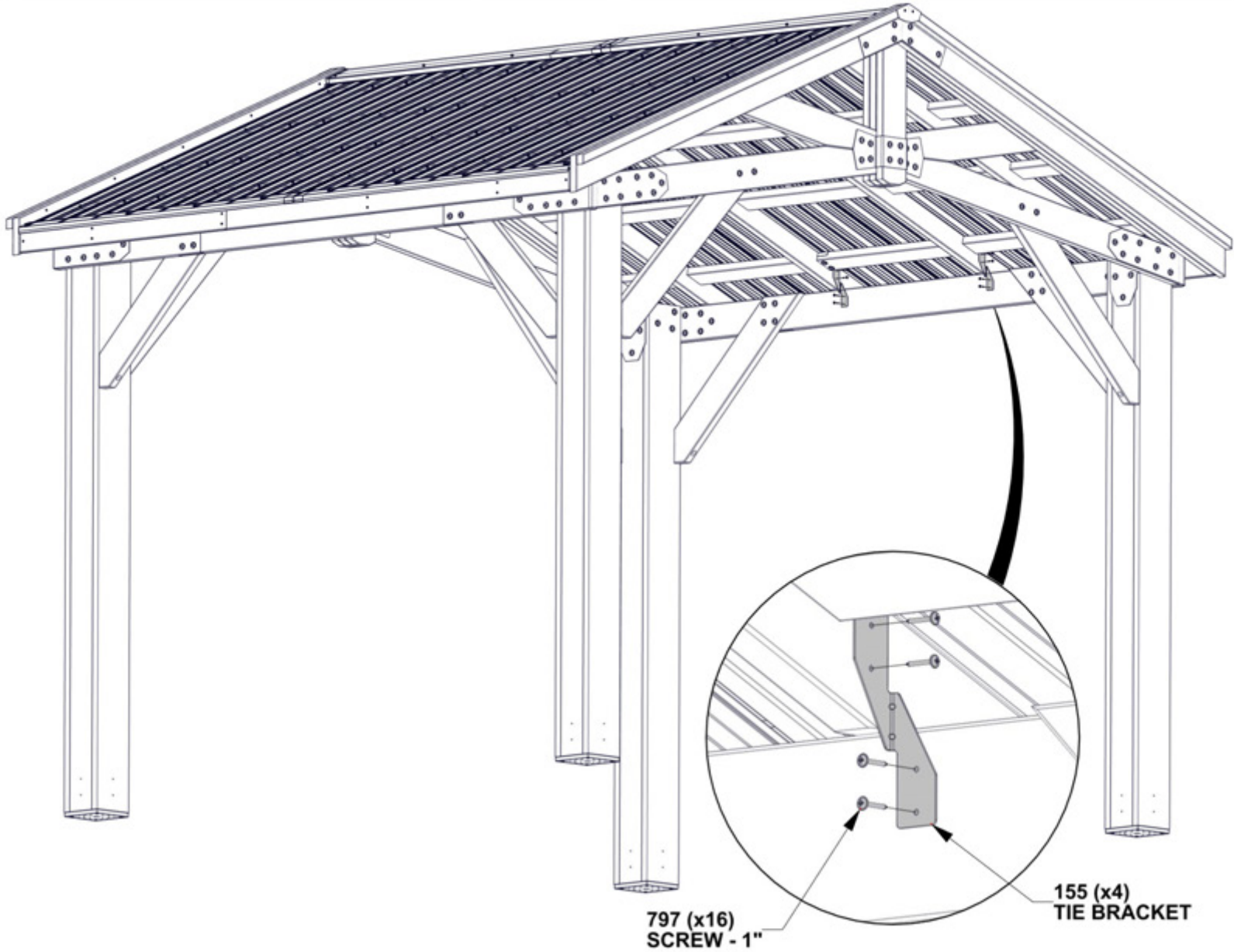

797 (x16)
SCREW - 1"

155 (x4)
TIE BRACKET

STEP 20 - GAZEBO ASSEMBLY

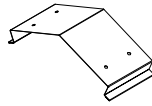

A4M01127 | RIDGE CAP SPLICE
(x1)

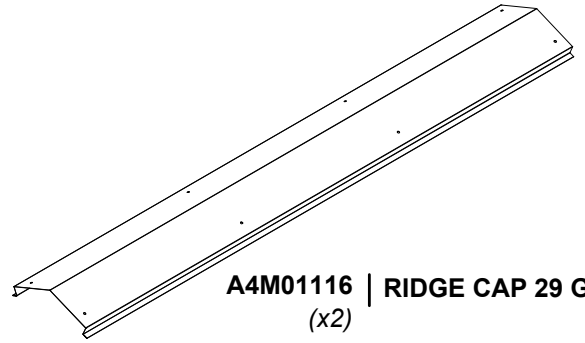

A4M01116 | RIDGE CAP 29 GA
(x2)

RIDGE CAP ASSEMBLY PREPARATION

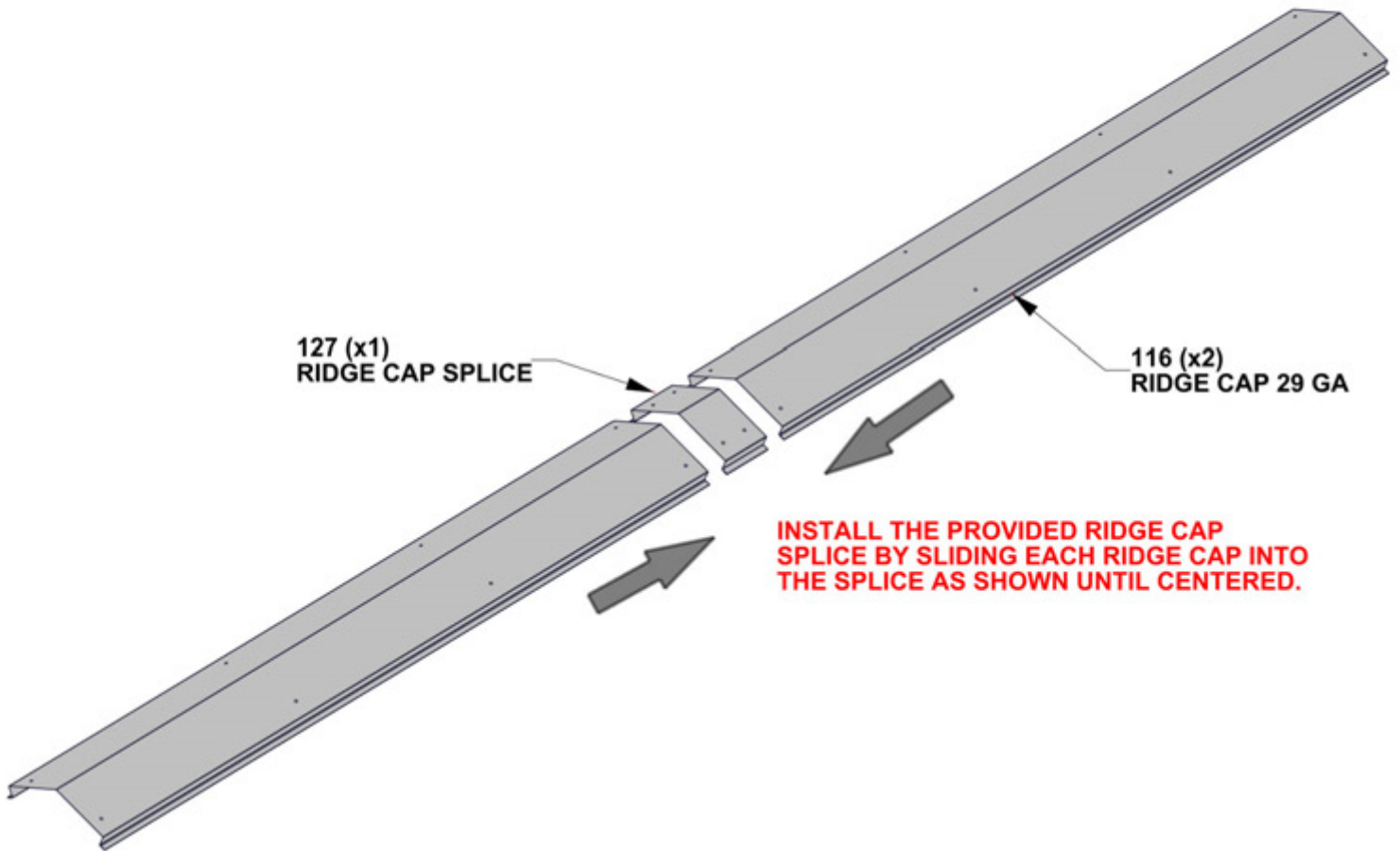

127 (x1)
RIDGE CAP SPLICE

116 (x2)
RIDGE CAP 29 GA

INSTALL THE PROVIDED RIDGE CAP SPLICE BY SLIDING EACH RIDGE CAP INTO THE SPLICE AS SHOWN UNTIL CENTERED.

STEP 21 - GAZEBO ASSEMBLY

QTY	PART NUMBER	DESCRIPTION
16	H100833	SCREW WOODGRIP 10x3/4



J9 | RIDGE CAP STIFFENER-W4L13590
 (x2) | 15/16"x2 3/8"x47 5/8" (24x60x1210)



J10 | RIDGE CAP STIFFENER-W4L13591
 (x2) | 15/16"x2 3/8"x69 5/16" (24x60x1760)

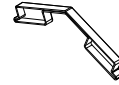

A6P00398 | RIDGE CAP PROTECTOR
 (x2)

ASSEMBLE BY ALIGNING THE HOLES ON EACH RIDGE CAP TO THE HOLES IN THE RIDGE CAP SPLICE.
FINAL LENGTH - 9'-9" [2974mm]

REMOVE SPACERS FROM RIDGE CAP PROTECTORS BEFORE INSTALLING.

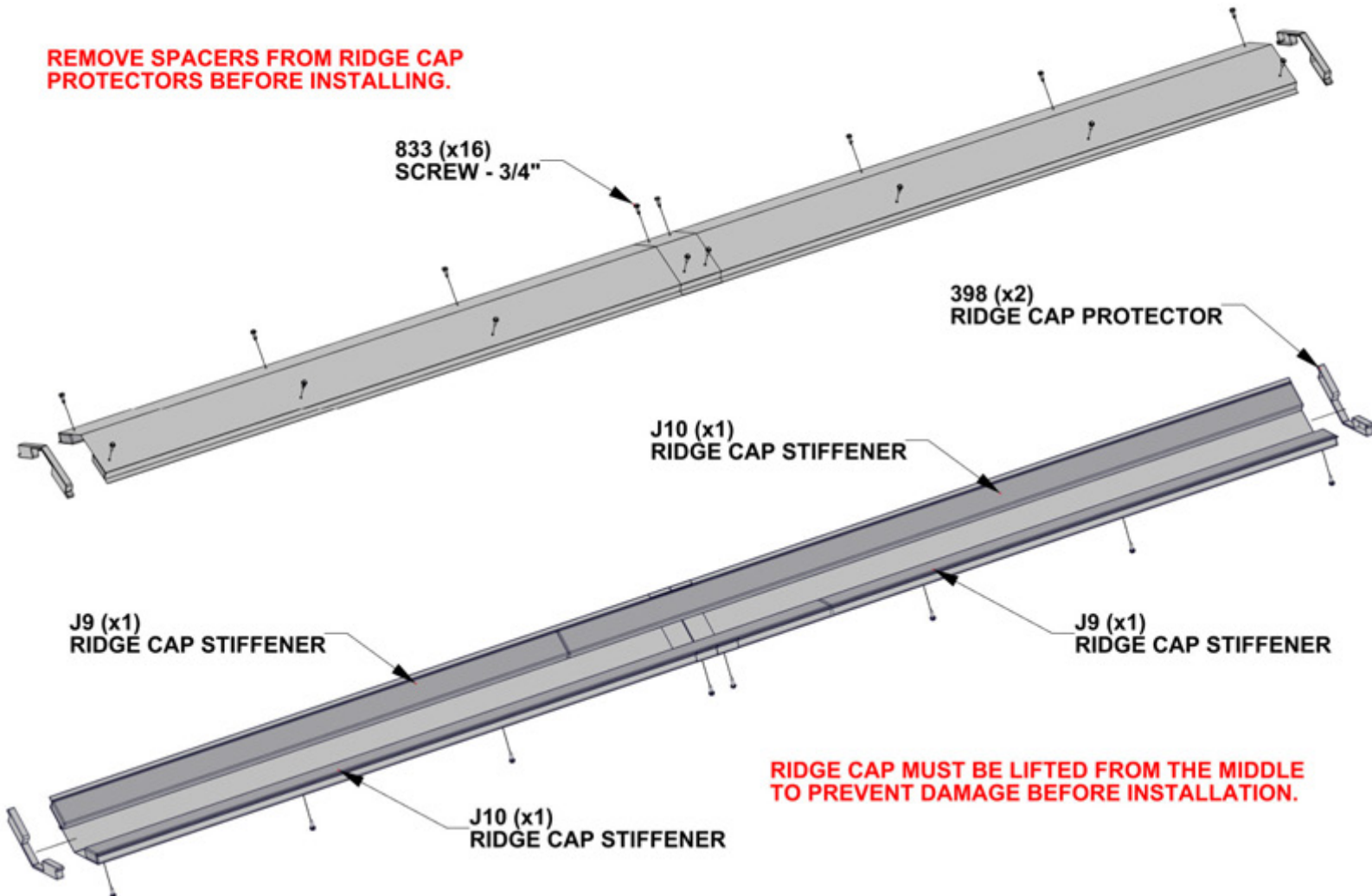

STEP 22 - GAZEBO ASSEMBLY

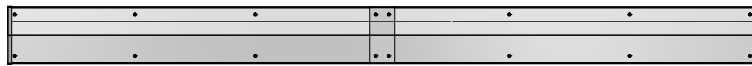

RIDGE CAP ASSEMBLY FROM PREVIOUS STEP

QTY	PART NUMBER	DESCRIPTION
16	H100392	SCREW PWH 8x3/4 BLK

**DO NOT CLIMB ON ROOF TO INSTALL:
RIDGE CAP HAS BEEN DESIGNED TO
INSTALL WITH THE USE OF A LADDER.**

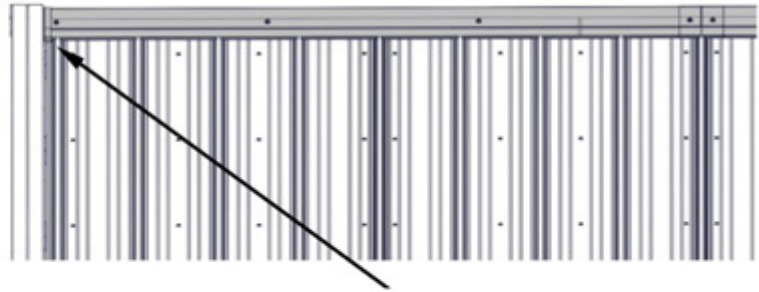
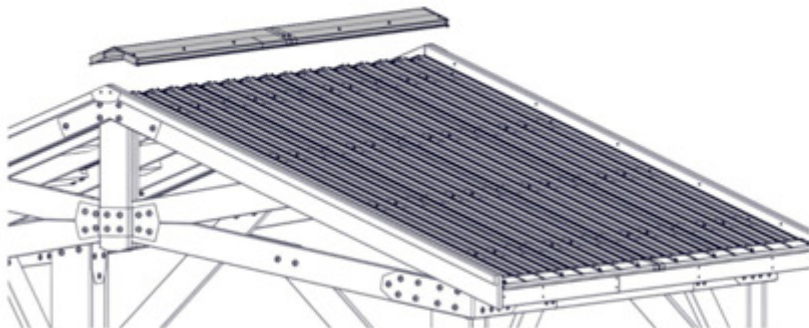

USING AN ADULT HELPER, SLIDE RIDGE CAP ASSEMBLY ACROSS THE ROOF RIDGE UNTIL BOTH ENDS SIT INSIDE RAFTERS AS SHOWN.

FOR PROPER INSTALLATION, USE AN ADULT HELPER TO KEEP DOWNWARD PRESSURE ON THE RIDGE CAP WHILE SCREWING IN SCREWS.

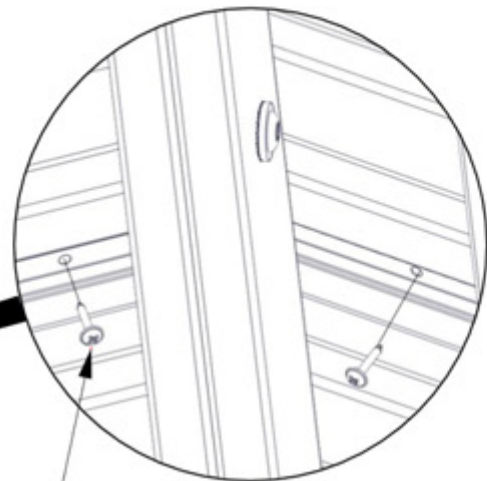
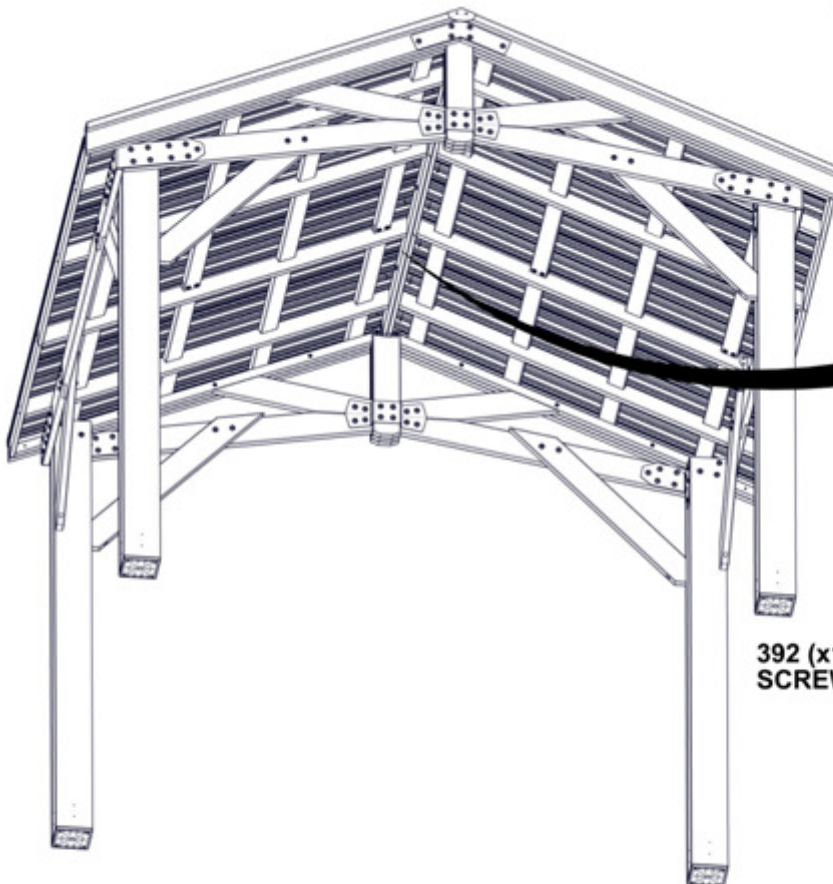

INSTALL SCREWS THROUGH PILOT HOLES IN ROOF PANELS INTO RIDGE CAP STIFFENER BOARDS.

392 (x16)
SCREW - 3/4"

STEP 23 - GAZEBO ASSEMBLY

QTY	PART NUMBER	DESCRIPTION
32	H100471	LAG SCREW WH 5/16x1 1/2 BLK



A4M01793 | POST ANCHORING PLATE
(x8)



A4M01794 | POST PLATE
(x8)

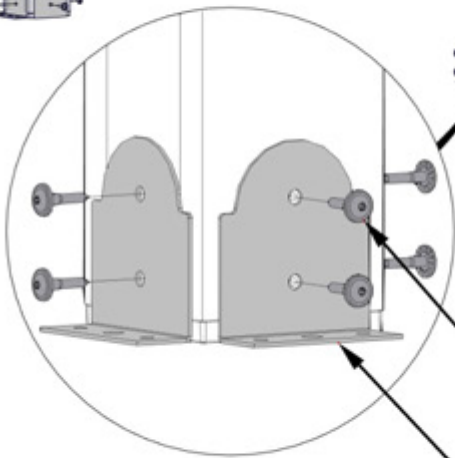
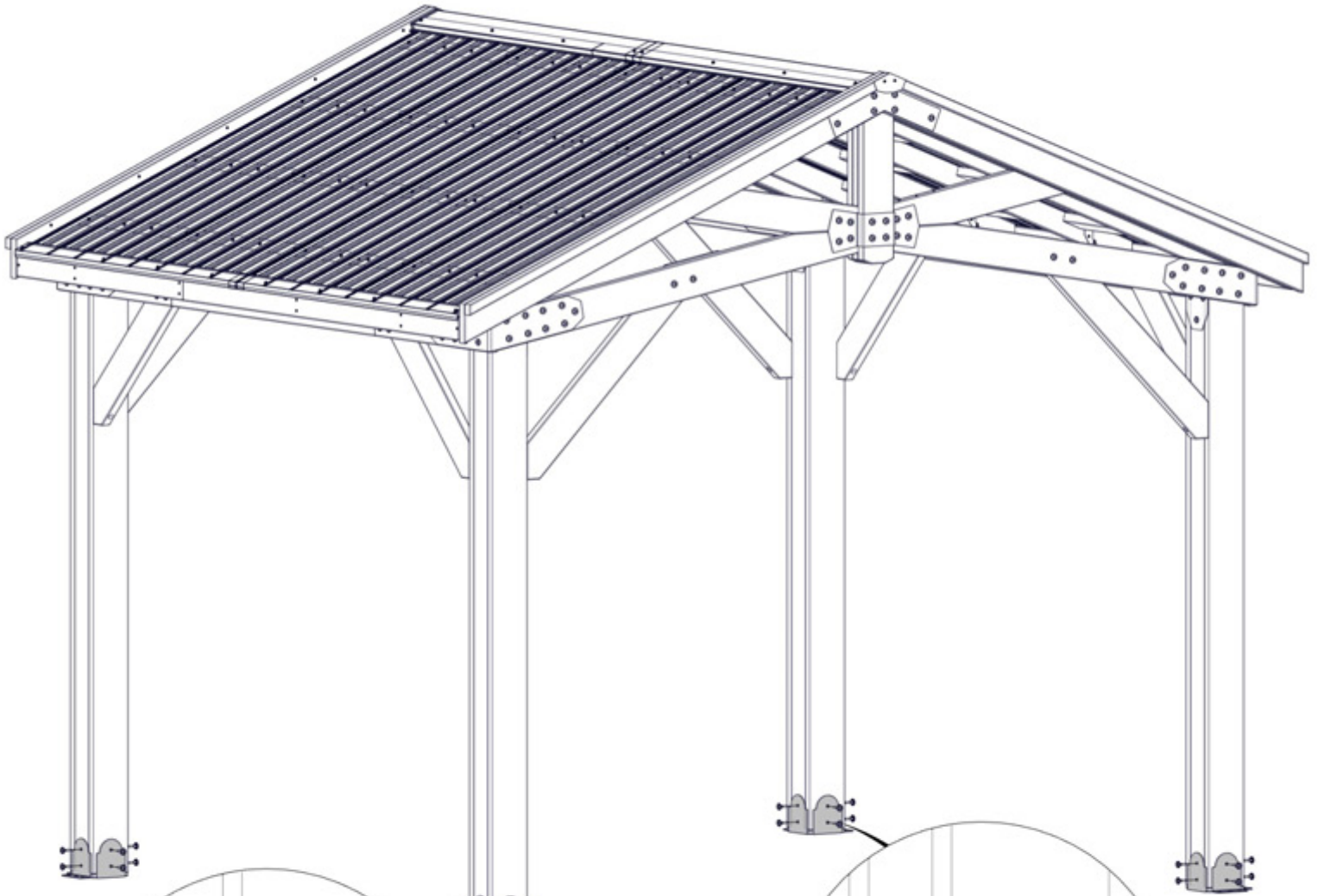

471 (x32)
LAG SCREW - 1 1/2"

1793 (x8)
POST ANCHORING PLATE

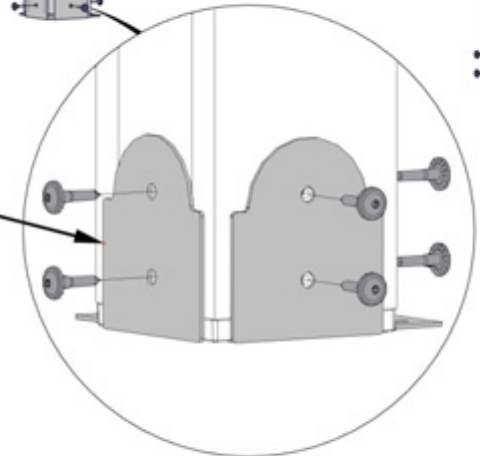

1794 (x8)
POST PLATE

STEP 24 - GAZEBO ASSEMBLY

QTY	PART NUMBER	DESCRIPTION
2	H100200	SCREW PFH 8x1 1/2 BLK



A100241 | BYD ID TAG
(x1)

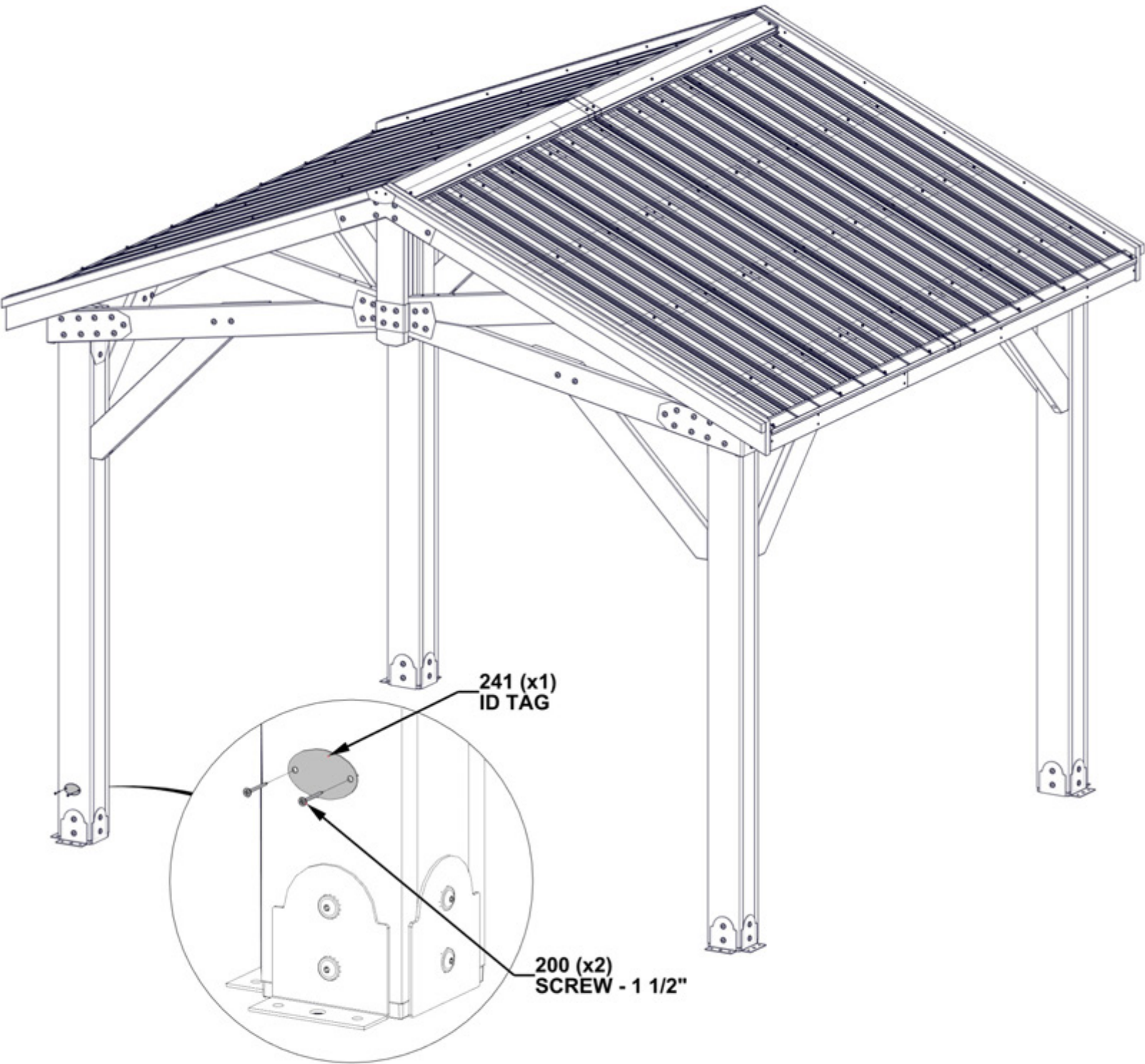

STEP 25 - GAZEBO ASSEMBLY

QTY	PART NUMBER	DESCRIPTION
16	H100630	WASHER FLAT 8x19 BLK
16	H100120	CONCRETE ANCHOR 1/4"x2"

MANUFACTURER RECOMMENDS INSTALLATION ON CONCRETE SURFACE OR CONCRETE POST PADS. SEE BELOW.

FOR INSTALLATION ON WOOD DECK, YOU MUST ENSURE THERE IS AMPLE STRUCTURAL SUPPORT UNDER DECK. HARDWARE NOT INCLUDED.

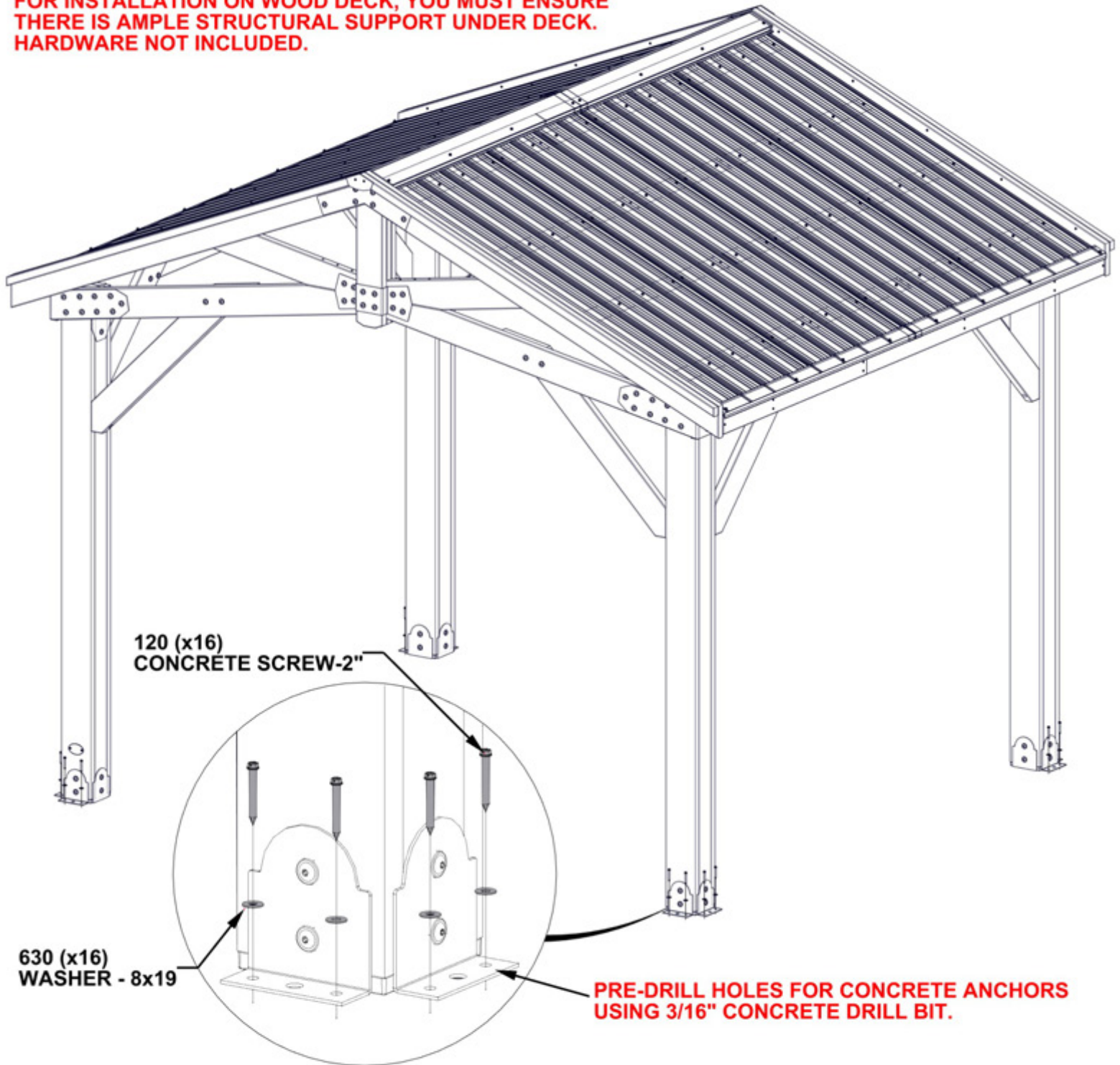

PowerPort™

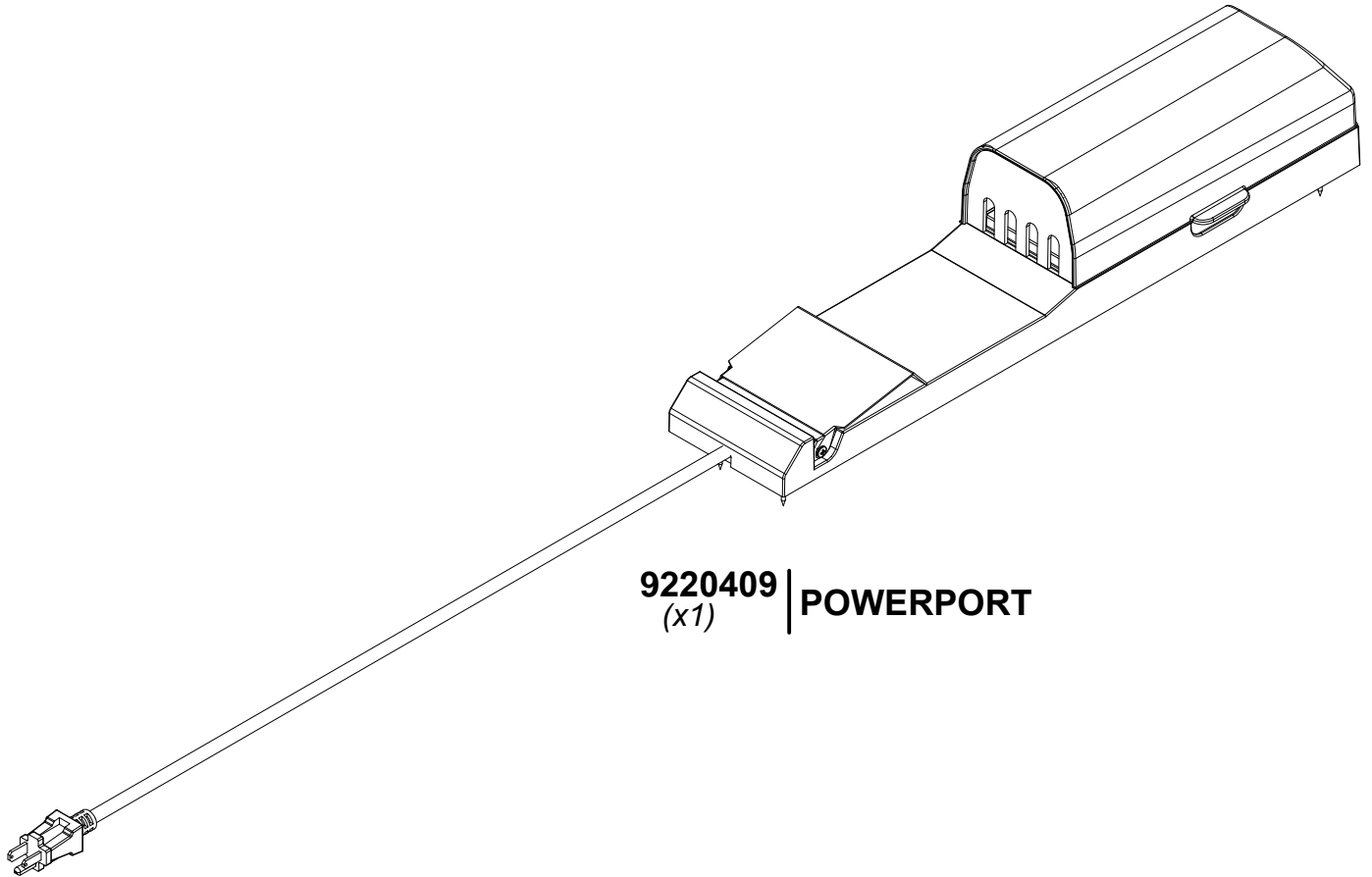

9220409 | **POWERPORT**
(x1)

FOR POWERPORT INSTALLATION REFER TO ASSEMBLY INSTRUCTIONS THAT COME PACKAGED WITH THE POWERPORT KIT. INSTALL ON ANY POST THAT IS DESIRED. FOLLOW DIRECTIONS FOR PROPER INSTALLATION.